

Atomizer Air Humidifiers

Type DG4 / DG8



Preliminary Note:

A word about water and atomising systems

All atomising humidifiers operate based on the principle that water in the form of very fine aerosol droplets may be atomised and subsequently evaporated.

Because tap water contains various components in addition to pure water (H₂O), solids remain behind after evaporation, such as calcium or other minerals. These form a fine dust in the area of evaporation. The build up of dust can be prevented by using fully demineralised water. Reverse osmosis systems, for example, are well-suited for this type of water treatment.

When drinking water is used, mineral deposits may form on the water pan and water level area. These deposits must be removed during regular maintenance. Maintenance work can be reduced by using fully demineralised water.

Consult your HygroMatik specialists. We will answer any questions you may have concerning water and advise you on the installation and initial operation of your HygroMatik atomising system.

Copyright HygroMatik GmbH

DG 29.10.2009

Information in this manual is subject to change or alteration without prior notice.



WARNING! All work to be performed by trained personnel only. All electrical installation and servicing of the electrical components of this unit to be performed by qualified electricians only. Disconnect power supply before installation and servicing!

1. Introduction	4
1.1 Directions for Use	5
1.2 Typographic Distinctions	5
1.3 Documentation	5
2. Safety Notes	6
2.1 Overview	6
2.2 Guidelines for Safe Operation	7
2.3 Accident Prevention Regulations	7
2.4 Disposal after Dismantling	8
3. Transport	9
3.1 Packing	10
3.2 Interim Storage	10
3.3 Check for Complete and Correct Delivery of Goods	10
3.4 Carton outer Size and Weight	10
3.5 Included in the Delivery	11
4. Operation	12
4.1 Mode of operation	12
4.2 Water level control	13
4.3 Overflow function:(only DG8)	14
5. Start up	16
6. Installation	17
6.1 Mechanical installation	17
6.2 Installation of DG	18
7. Water Installation	19
7.1 Safety overflow	20
7.2 Safety overflow (electrical) and water leveladjustments	20
8. Electrical installation	21
8.1 Electrical installation	21
8.2 Hygrostat installation	21
8.3 Control box NR	21
9. Maintenance	22
10. Faults	23
10.1 Output fall off	23
10.2 No water in the pan	23
10.3 Water fault (Red lamp on control box NR)	23
11. EC Declaration of Conformity	24
12. Wiring Diagrams	25
13. Spare Parts	32
14. Technical data	34

1. Introduction

Dear Customer,

Thank you for choosing a HygroMatik atomizing air humidifier.

The HygroMatik atomizing air humidifier represent the latest in humidification technology.

They will impress you with their safety, ease of use and economical operation.

In order to operate your HygroMatik atomizing air humidifier safely, properly and efficiently, please read these operating instructions.

Employ your HygroMatik atomizing air humidifier only in sound condition and as directed. Consider potential hazards and safety issues and follow all the recommendations in these instructions.

Microatomization and fast freshwater exchange ensure optimum operating properties. Our range of products includes devices with circulation air blower for fast, uniform moisture distribution and also still humidification (without circulation blower) for special applications.

The control box NR (only for DG8) operates to an extraordinary high degree of precision and automatic controls 1 to 4 air humidifiers. The integrated automatic freshwater control ensures that the residual water in the unit is essentially used up after reaching the set humidity level and, when restarted, freshwater is immediately fed to the unit and atomized. The unit can be set to a range of 30-90% relative humidity with the room hygostat RH1 and the duct humidistat KF 1.

If you have additional questions, please contact us:

Tel.: +49-(0)4193 / 895-0 (Main Number)

Tel.: +49-(0)4193 / 895-293 (Technical Support Hotline)

Fax: +49-(0)4193 / 895-33

e-mail: hot1@HygroMatik.de

Internet: www.hygroamatik.de

For all technical questions or spare parts orders, please be prepared to provide unit type and serial number (see name plate on the unit).

1.1 Directions for Use

The HygroMatik atomizing air humidifier is intended for air moistening.

Proper usage also entails following HygroMatik's instructions for installation, dismantling, reassembly, initial operation and operation and maintenance, as well as disposal procedures.

Only qualified, authorized personnel may operate or service the unit. Workers who transport or service the unit must have read and understood the relevant sections of the operating instructions, especially the section "Safety Notes." In addition, staff must receive safety training about potential hazards from the operator. Place a copy of the operating instructions at the location where the unit is operated.

1.2 Typographic Distinctions

- preceded by a bullet: general specifications.
 - » preceded by an arrow: Procedures for servicing or maintenance which should or must be performed in the indicated order.
 - Installationstep which must be checked off.
- italics* Terms used with graphics or drawings..

1.3 Documentation

Retention

Please retain these operating instructions in a secure, always accessible location. If the product is resold, turn the documentation over to the new operator. If the documentation is lost, please contact HygroMatik.

Versions in Other Languages

These operating instructions are available in several languages. If interested, please contact HygroMatik or your HygroMatik dealer.

2. Safety Notes

2.1 Overview

These safety notes are required by law. They promote workplace safety and accident prevention.

Warnings and Safety Symbols

The safety symbols below identify sections containing warnings about hazards or potential dangers. Please familiarize yourself with these symbols.



Warning: Failure to observe this warning may result in serious injury or death and/or damage to the unit.



Danger, Hazardous Voltage: Hazardous electrical current! Failure to observe this warning may result in injury or even serious injury or death.



Note: Please find this sticker on a component that is important to maintain. A detailed maintenance description is in the technical manual. Reading the according text passages is important for a proper use of the device.



Reminder: Materials and consumables must be handled and/or disposed of as required by law.



Note: Appears before explanations or cross-references which refer to other sections of the operating instructions.

2.2 Guidelines for Safe Operation

Overview

Obey all safety notes and warnings present on the unit.

In case of a malfunction, switch off the unit immediately and prevent a restart. Repair malfunctions promptly.

After any repair work, have qualified personnel check the safe operation of the unit.

Use original spare parts only.

Additional national safety regulations also fully apply to the operation of this unit.

We recommend the use of an external main circuit breaker.

Please ensure a safe handling of all auxiliary means like ladders, lifting platforms etc. during installation in order to avoid accidents.

Please do not directly install the unit above machines or wetness sensitive equipment.

Ambient air temperature 5°C to 45°C.

2.3 Accident Prevention Regulations



Comply with the accident prevention regulation Accident Prevention Regulation Electrical Systems and Equipment to prevent injury to yourself and others.

Operation of the Unit

Do not perform any work which compromises the safety of the unit.

Regularly check that all safety and monitoring devices are functioning normally.

Do not remove or disable safety devices.

Installation, dismantling, maintenance and repair of the unit

Disconnect unit components from power supply prior to maintenance or repair work.

Attaching or installing **additional components** is permitted only with the **written consent** of the manufacturer.

Electrical



Work on the electrical system must be performed by qualified personnel.

Disconnect unit components from power supply prior to work

In case of a malfunction in the electrical power supply, switch off

the unit immediately.

Use only original fuses with the appropriate amperage rating.

Regularly check the unit's electrical equipment. Promptly repair any damage, such as loose connections or damaged wiring. After proper electrical installation or repair, test all safety mechanisms (such as grounding resistance).

Protection class:

HygroMatik atomizing air humidifiers are IP24-protected. Make sure that the unit is protected from drips in its installed location.

Installing a atomizing air humidifier in a room without water discharge requires safety devices to protect against water leakages.

2.4 Disposal after Dismantling



Note: The operator is responsible for the disposal of unit components as required by law.

3. Transport

Carefully transport, load or unload the atomizer to avoid any damage.

Pay attention to the pictograms on the carton.

Upon receipt of the unit, make sure that:

- Type and serial number on the type plate correspond with order and delivery notes.
- That the equipment parts are complete and in perfect condition.

Note: File immediately a written report to your shipping agent in case of transport damage.

3.1 Packing



Note: Notice the symbols affixed to the packing box.

3.2 Interim Storage

Store the unit in a dry place and protect from frost.

3.3 Check for Complete and Correct Delivery of Goods

Upon receipt of the unit, confirm that:

- the type and serial number on the name plate match those specified in the order and delivery documents and
- the equipment is complete and all parts are in perfect condition



Note: In case of damage during shipment or missing parts, immediately notify the carrier or supplier in writing.

Time limits for filing freight claims with shipping companies are*:

Shipping Companies	After Receipt of Goods
Mail	no later than 24 hours
Rail	no later than 7 days
Truck and Rail Carriers	no later than 4 days
Parcel Service	immediately

* Time limits for some services subject to change.

3.4 Carton outer Size and Weight

Type*	Height [cm]	Width [cm]	Depth [cm]
DG4	51	51	33
DG8	65	65	34

3.5 Included in the Delivery

The delivery includes:

- Selected atomizing air humidifier
- Water installation hose 1,5m, 1/2"
- 4 x 1,50m chains incl. 4 carabiner for mounting chains (DG4 mit 3 x 1,5 m Chain incl. 3 carabiner)
- Operating Instructions for the atomizing air humidifier

4. Operation

4.1 Mode of operation

HygroMatik atomizing air humidifiers work on the centrifugal principle.

There is a water pan in which a normal operating water level is maintained. In case of the DG8 the regulating system consists of a two-step control switch (5) and a water solenoid valve (6). In case of the DG4, it is a mechanical float. The water is drawn up on the outside of the rotating water conveying cone until it reaches the atomizer disc (2). This causes a film on the down-side of the disc. This film is forced to the edge of the disc by petal-forces of the rotating disc, where it leaves the disc with high forces and hits a baffle grid. (3). This is the point where it atomizes into fine droplets. They are suspended in the air and evaporate. The humidity is immediately taken up by the air. For higher rates of humidification, the evaporative effect is intensified by the fan and the carrier air flow (11). The carrier air flow is not blown through - but over - the bonnet of the humidifier, in order not to suck in the dust from the air of the room. The water-level in the base pan decreases due to water atomizing and water is automatically refilled by the regulating system and the two-step control flow switch (DG8). At DG4 the water level is controlled by a mechanical float, which opens a valve at decreasing water level. So water can flow in the basic pan again. A safety overflow ensures a controlled draining in case of water overflow. A signal is sent to the control box NR (DG8).

4.2 Water level control

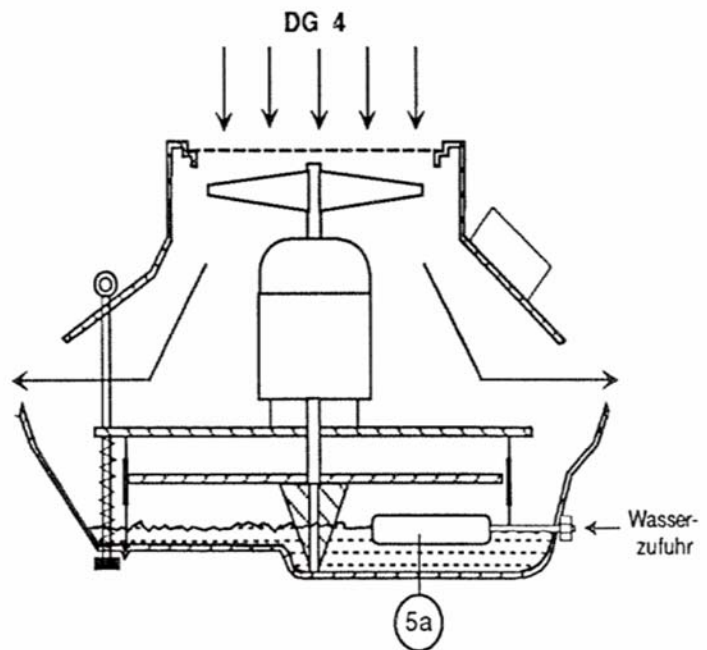

The waterlevel in the base tube is controlled by the lower flow switch of the two-step flow switch.

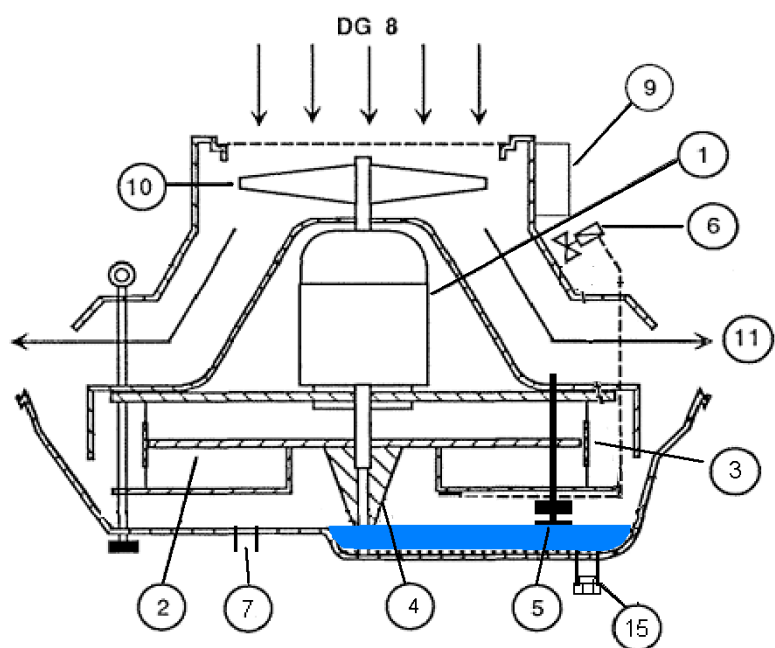

4.3 Overflow function:(only DG8)

In case of a defective (permanent open) solenoid valve surplus water will be drained by the mechanical overflow (pos. 7).

In case of a defective or blocked two-step control switch the unit automatically switches off the water supply. At the same time a signal is send to the control box NR (option) and a lamp indicates a fault.

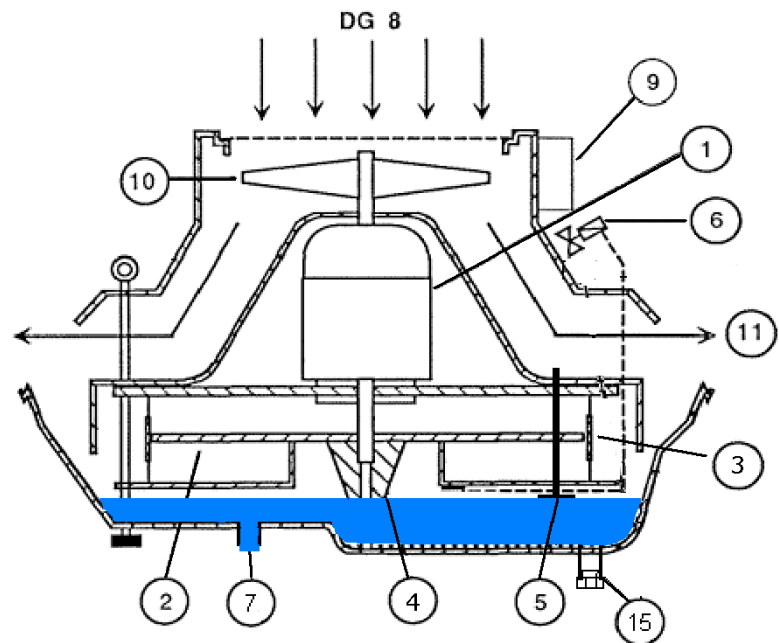

1. Electric motor
2. Atomizer disc
3. Baffle grid
4. Water conveying cone
5. Two-step control flow switch - only DG 8
- 5a. Mechanical float - only DG 4
6. Water solenoid valve for operating level
7. Mechanical overflow

- 9. Terminal box
- 10. Fan impeller
- 11. Carrier air flow
- 15. Drain connection

5. Start up

- Open tap water valve
- Only DG4: check max. water level in the pan. Adjust water level by moving the red control lever
- Insert main fuses
- Only DG8: switch „On“ the control box NR.
- Adjust the hygrostat to humidity 100%
- Only DG8: check maximum water level
- Check the rotation (arrow). The atomizer air humidifier only works correctly with right rotation. At wrong rotation you have to change two phases (DG8). At wrong DG4 rotation you have to check the correct clamp connection
- Adjust the hygrostat to setpoint 30% - 90% humidity

6. Installation



Warning: Installation of this unit needs to be attempted only by qualified staff. We accept no liability for damage due to faulty installation.

Obey all safety notes and warnings present on the unit.

During installation the unit must be disconnected from its power supply.

Attaching or installing additional components is permitted only with the written consent of the manufacturer, or else the warranty is void.

6.1 Mechanical installation

Install approximately in the centre over a gangway if possible (to facilitate maintenance). Be aware of a proper fixation of the air atomizer at the ceiling.

For ceiling heights up to 3.5 m, mount directly under the ceiling; in case of higher ceilings, suspend such, that the bottom of the humidifier is approx. 2.5 - 3 m above the floor. Minimum ceiling and lateral clearances as shown in installation drawing.

When suspension chains are used, it is essential to spread and fix them at 4 points, otherwise there is a risk of the unit rotating at start-up with breakage of the water line. The humidifier must be suspended precisely horizontally (length or shorten the suspension chains).

6.2 Installation of DG

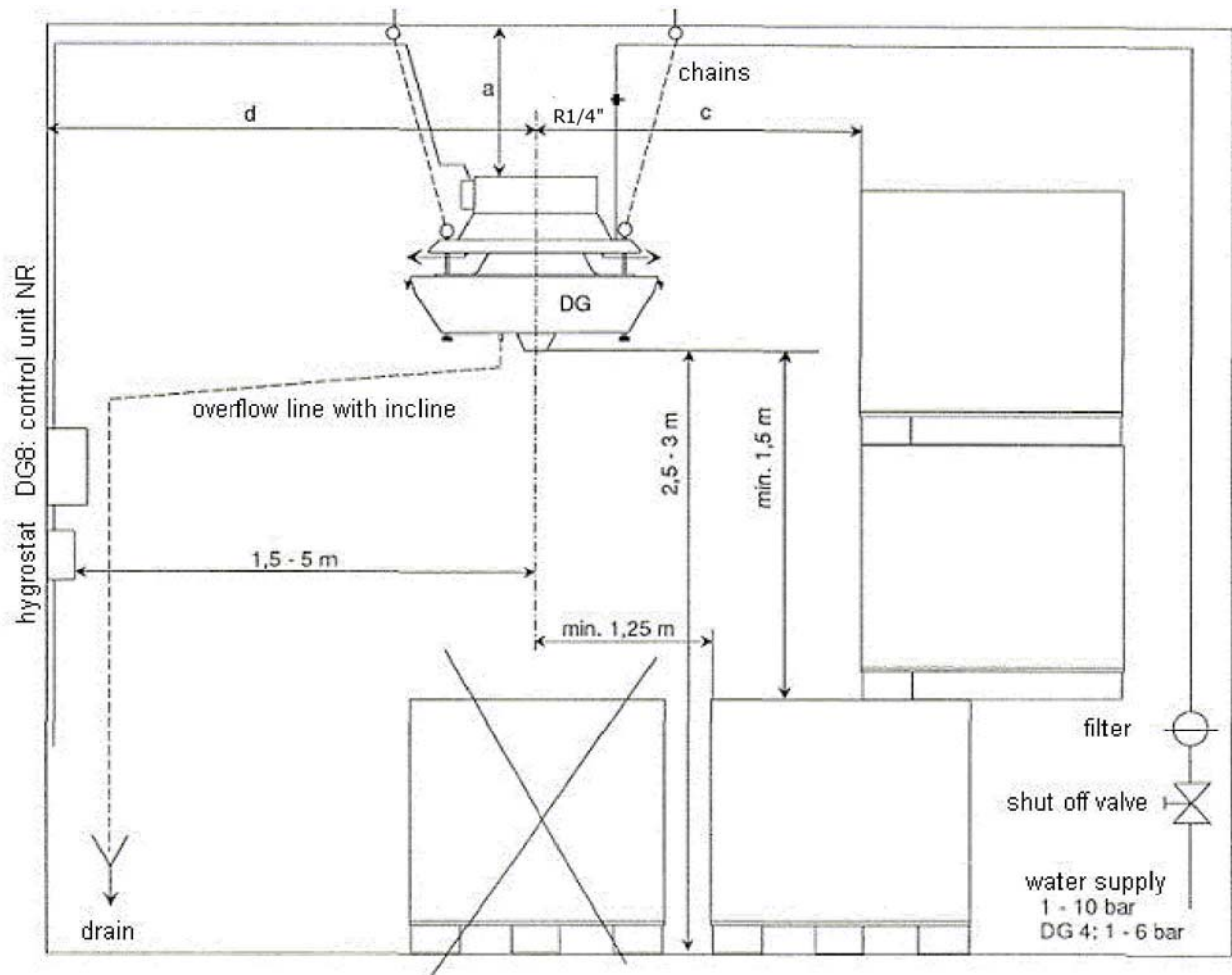

a: DG4 min. 0,4 m

DG8 min. 0,8 m

b: DG4 min. 0,4 m

DG8 min. 0,7 m

c: DG4 min. 1,0 m

DG8 min. 2,5 m

d: DG4 min. 1,0 m

DG8 min. 2,5 m

7. Water Installation



Warning: When prepare the water installation, note the following:

- Have all work performed by an expert
- Disconnect power supply before installation
- Obey local public utility regulations
- Verify that necessary safety measures have been taken – in compliance with either German Technical and Scientific Association for gas and water (DVGW) guidelines (German Institute for Standardization [DIN] 1988) or local regulations – to eliminate backflow of polluted water into drinking water treatment facilities. This can mean installing a backflow preventer
- The water supply temperature may not exceed 40° C.
- Water installation pressure DG8 100 - 1000 kPa (1-10 bar) water installation pressure DG4 100- 600 kPa (1-6bar)

Please only use the water supply hose that has been delivered with the unit.



Warning: The water supply hose should not be bent.

The connection on the humidifier to the water feed line is a 1/4" BSP externally threaded nipple. With water pressure up to 1000 kPa, (DG4 max. 600 kPa) connect directly to the water main; otherwise use a pressure reducing valve. Min. working pressure, 100 kPa.

The water feed line should be brought down from the ceiling (otherwise condensation around the line might occur).

It is advisable to insert a dirt filter in the common feed line and a stopping valve for each humidifier.



7.1 Safety overflow

Install an overflow line with a continuous downward slope from the 1/2" nozzle on the water pan to the drain. Hose and pipe size should have a minimum diameter of 15mm (depending on the downward gradient).

7.2 Safety overflow (electrical) and water level-adjustments

The level in the water pan is controlled by means of a regulating system consisting of a two-step flow switch and a solenoid valve, fitted as standard equipment. In addition an overflow control system may be fitted which immediately shuts off the water feed when the max. water level is reached and signals the malfunction of the primary level control by a red warning light at the control box NR. The air humidifier continues to operate normally, but with a higher water level.

- Operation - water filling: DG4 / DG8 approx. 0.5 l
- DG4: max. water supply pressure 600 kPa
- DG8: max. water supply pressure 1000 kPa
- Operation water level marked by chamfer in the pan factory provided approx. 0.5l
- Adjustable water level by red control lever (DG4)

8. Electrical installation

8.1 Electrical installation

- All work must be carried out by qualified electricians
- Carry out the electrical installation in accordance to the electrical circuit diagram

Connect max. 4 atomizers to one control box NR.

Note: All NR units are equipped as standard with automatic freshwater control.

After the set humidity level has been reached, the solenoid-operated water valve „operating level“ switches off first, while the motor or the diffuser system continues to run for several minutes; thereby using up the water in the pan. When restarted, freshwater is immediately fed to the unit and atomized.

Caution: If the unit is briefly switched on and off by adjusting the hygostat, a time delay of approx. 5 minutes must elapse before the motor switches off.

- **Set the motor protection switch at the nominal amperage stated on the name plate.**
- Main fuses must be supplied by the customer. (See „Technical Data“)
- A 4A control fuse is incorporated to the terminal block in the control box NR.

8.2 Hygostat installation

Mount at a height of approx. 1.5 - 2 m on a column or inside wall at a point where normal atmospheric conditions prevail, not in direct sunlight and not above a source of heat. The hygostat should not be installed at outside walls. Distance from air humidifier, 1.5 m min. 5 m max.

8.3 Control box NR

Install at a place where it is easy to see, so that an indicated fault can be seen and cleared.

9. Maintenance



- Clean the waterlevel control unit depending on dirtiness cycle
- Remove and clean the pan (4 screws)
- Clean water feed cone
- DG8: remove two-step-control switch and clean it with a lot of water. Don't use chemical cleaner or grease!
- DG4: control the mechanical float and adjust it with the red adjusting lever
- Clean baffle grid. At strong calcination you can use a softening agent and a lot of water
- Clean safety overflow
- Check function and leakage of solenoid valve
- Check water hoses for leakage and damage
- Test the atomizer
- If necessary, adjust hygostat with measure instrument

10. Faults

10.1 Output fall off

If the humidification rate declines, or malfunction, check the following:

- Motor protection switch. If it cuts out repeatedly, have it checked by an electrician
- Main fuses
- Control fuse in the control box NR (only DG8)
- Set the selector dial on the RH hygrostat to 100% for a short period; the air humidifier should start up immediately
- Check the function of the solenoid valve.
- Check the function of the two-step control switch (DB8) or mechanical float (DG4). If it is dirty, you have to clean it

10.2 No water in the pan

- Check the function of the two-step control switch, the operating level and check the quantity of water filled into the pan. Also check and remove dirt of the two-step control switch
- If necessary, depending on the amount of water found, shift the float to a higher or lower position in the slotted hole in its holder
- DG8: Check the function of solenoid valve and the water filter in the water supply

10.3 Water fault (Red lamp on control box NR)

- Control water supply

11. EC Declaration of Conformity

HYGROMATIK[®]

Declaration of Conformity (EU)

according EU-directive Low Voltage 73/23/EEC, 93/68/EEC

Manufacturer: HYGROMATIK GmbH
Lise-Meitner-Str. 3, 24 558 Henstedt-Ulzburg

Product description: Aerosol humidifier for direct connection to the main water network.
Type: DG 4-8

This product is in accordance to the safety requirements of the EU-directive Low Voltage (LVD). This declaration will become invalid in case of product modification without consent of HYGROMATIK.

Applied harmonized standards:

- EN 60335 (VDE 0700)

Applied national standards and technical specifications:

- DIN VDE 0100

Henstedt-Ulzburg, December 2008

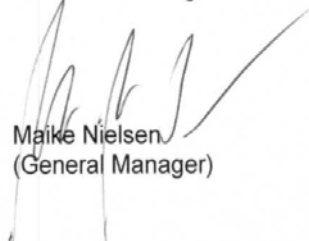

Maike Nielsen
(General Manager)

Dirc Menssing
(Technical Manager)

12. Wiring Diagrams

Legend for wiring diagrams DG

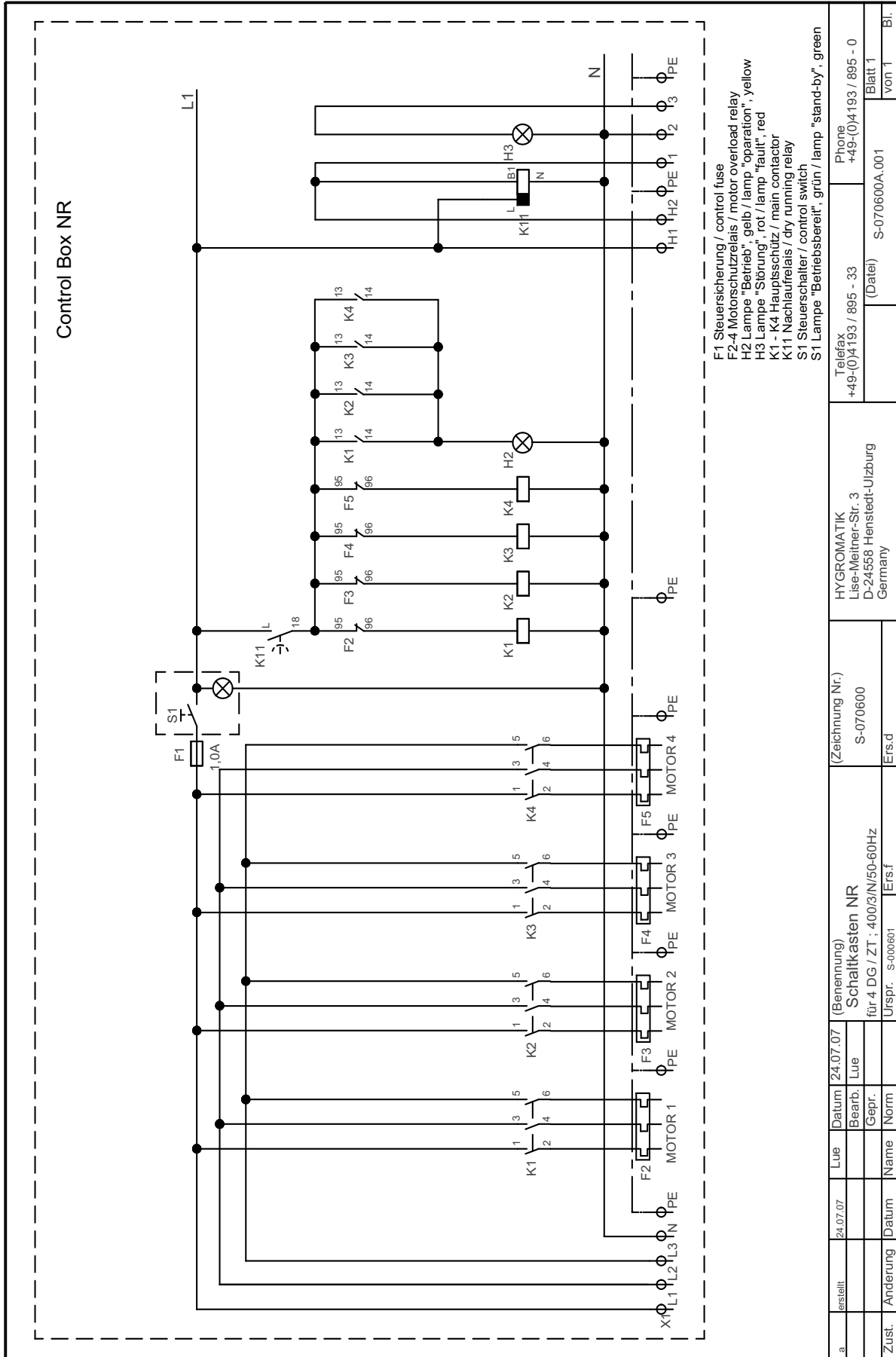
- b1 + b2 2-step-control switch for operation level and electrical safety overflow switch
- F1 Motor protection switch
- F1 Motor protection relais
- F1 Safety fuse, 4 A
- H1 LED „Stand-by" (green)
- H2 LED "Humidification" (yellow)
- H3 LED "Fault" (red)
- Hy Hygrostat
- K1 Main contactor
- K11 Delayed relais
- M1 Motor 380 V 3N~ 50 Hz
- M2 Motor 230 V 3N~ 50 Hz
- M3 Motor 230 V 1 N~ 50 Hz
- S1 Main switch
- Y1 Solenoid valve for automatic water feed



Control Box NR

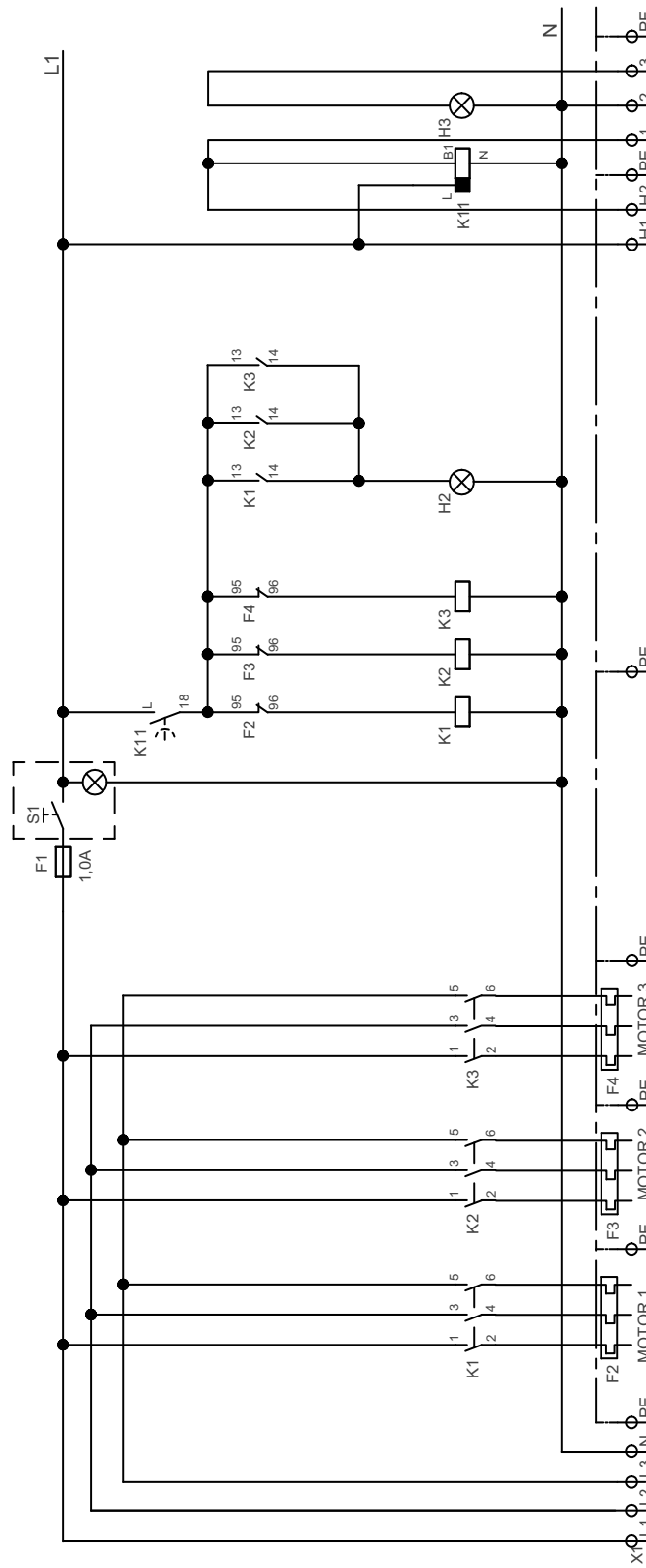

- F1 Steuersicherung / control fuse
- F2-4 Motorschutzrelais / motor overload relay
- H2 Lampe "Betrieb", gelb / lamp "operation", yellow
- H3 Lampe "Störung", rot / lamp "fault", red
- K1 - K3 Hauptsschütz / main contactor
- K11 Nachlaufrelais / dry running relay
- S1 Steuerschalter / control switch
- S1 Lampe "Betriebsbereit", grün / lamp "stand-by", green

a	Erstellt	24.07.07	Lue	Datum	24.07.07	(Benennung)	Schaltkasten NR		(Zeichnung Nr.)	HYGROMATIK		Telefax	Phone
				Bearb.	Lue		für 3 DG / ZT ; 400/3/N/50-60Hz		S-070601	Lies-Meiner-Str. 3		+49-(0)4193 / 895 - 33	+49-(0)4193 / 895 - 0
				Gepr.					Ers.d	D-24558 Heinstedt-Ulzburg		(Datei)	S-070601A.001
Zust.	Anderung	Datum	Name	Norm							Germany		Blatt 1
													von 1
													Bl.

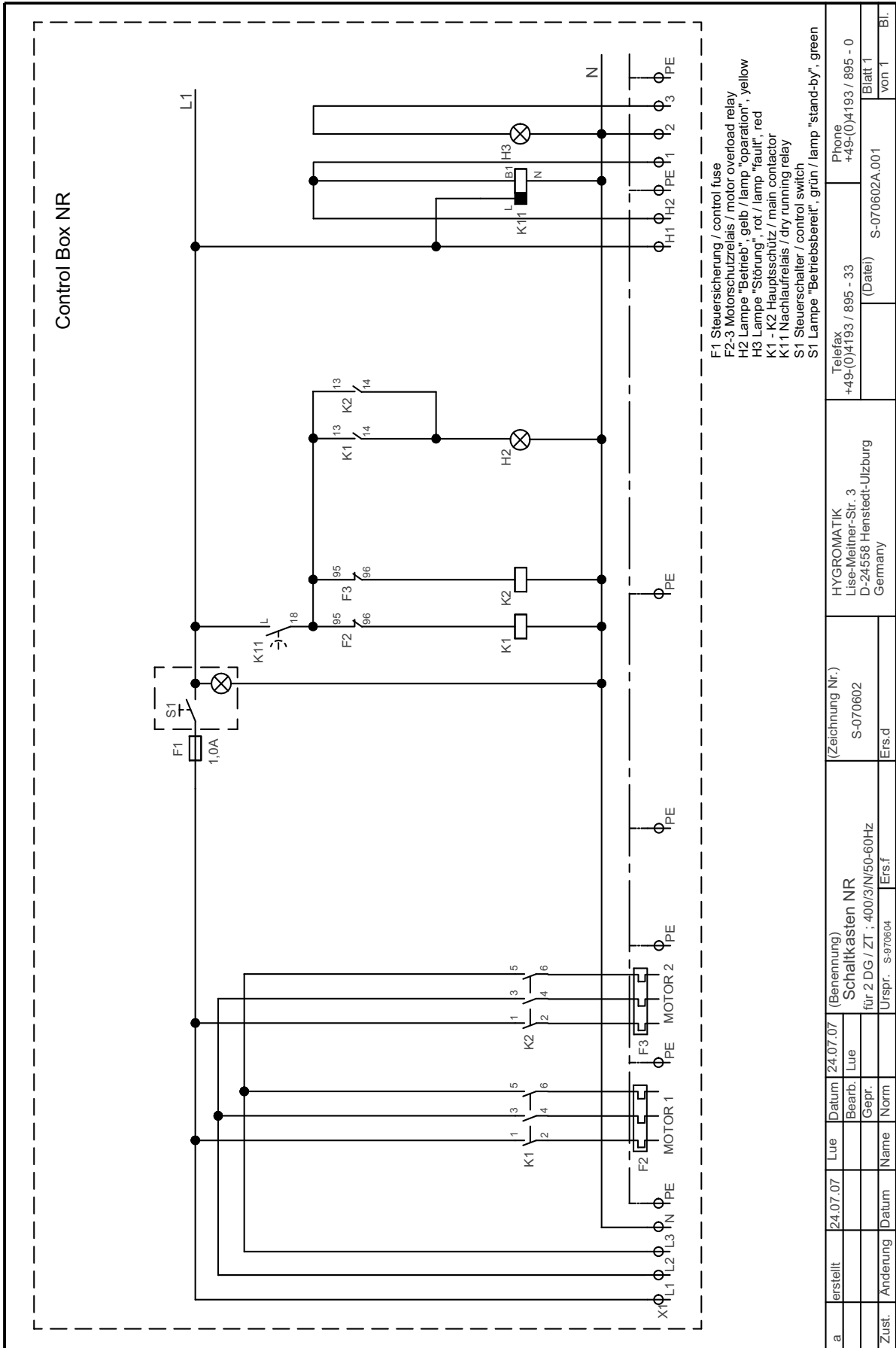

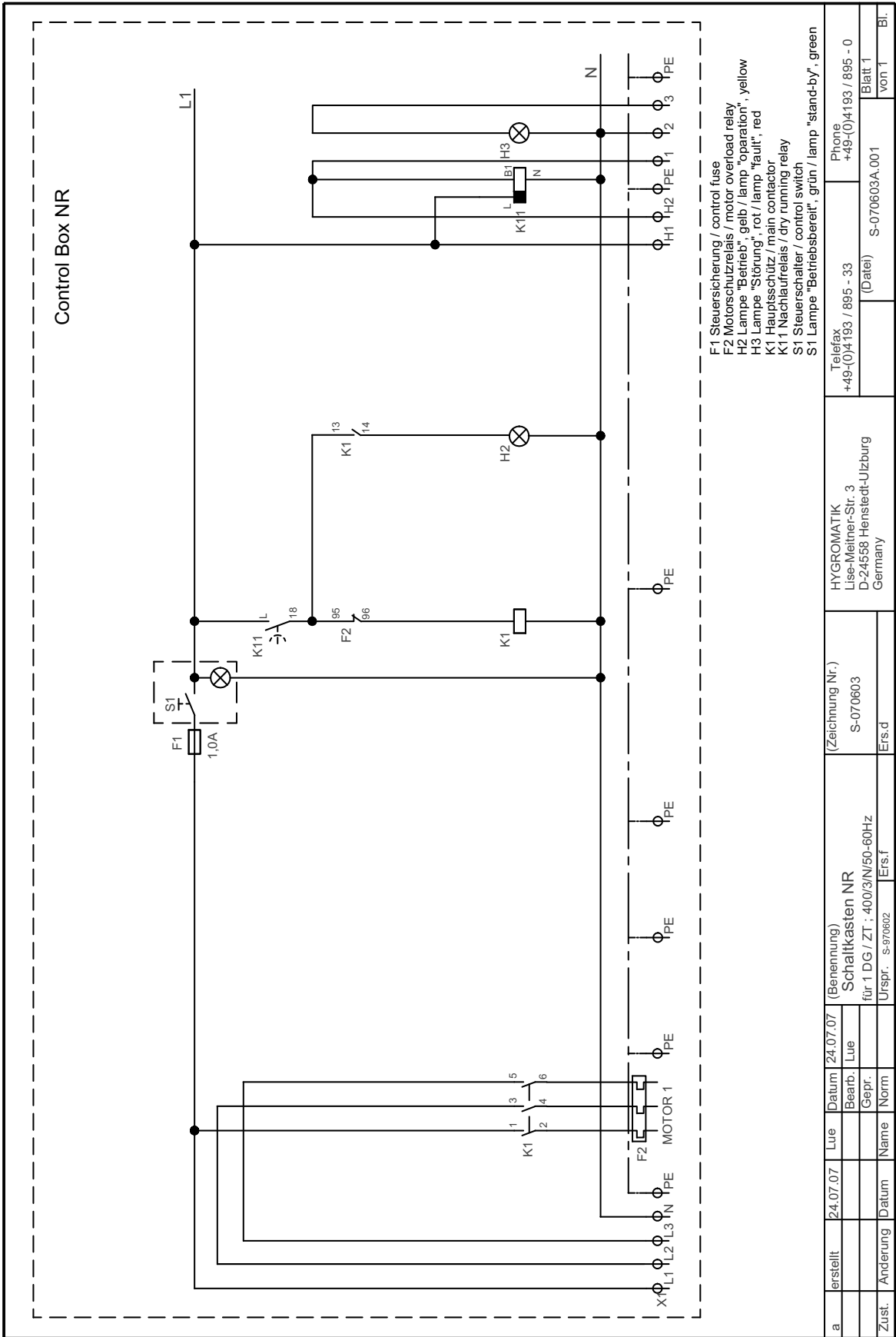

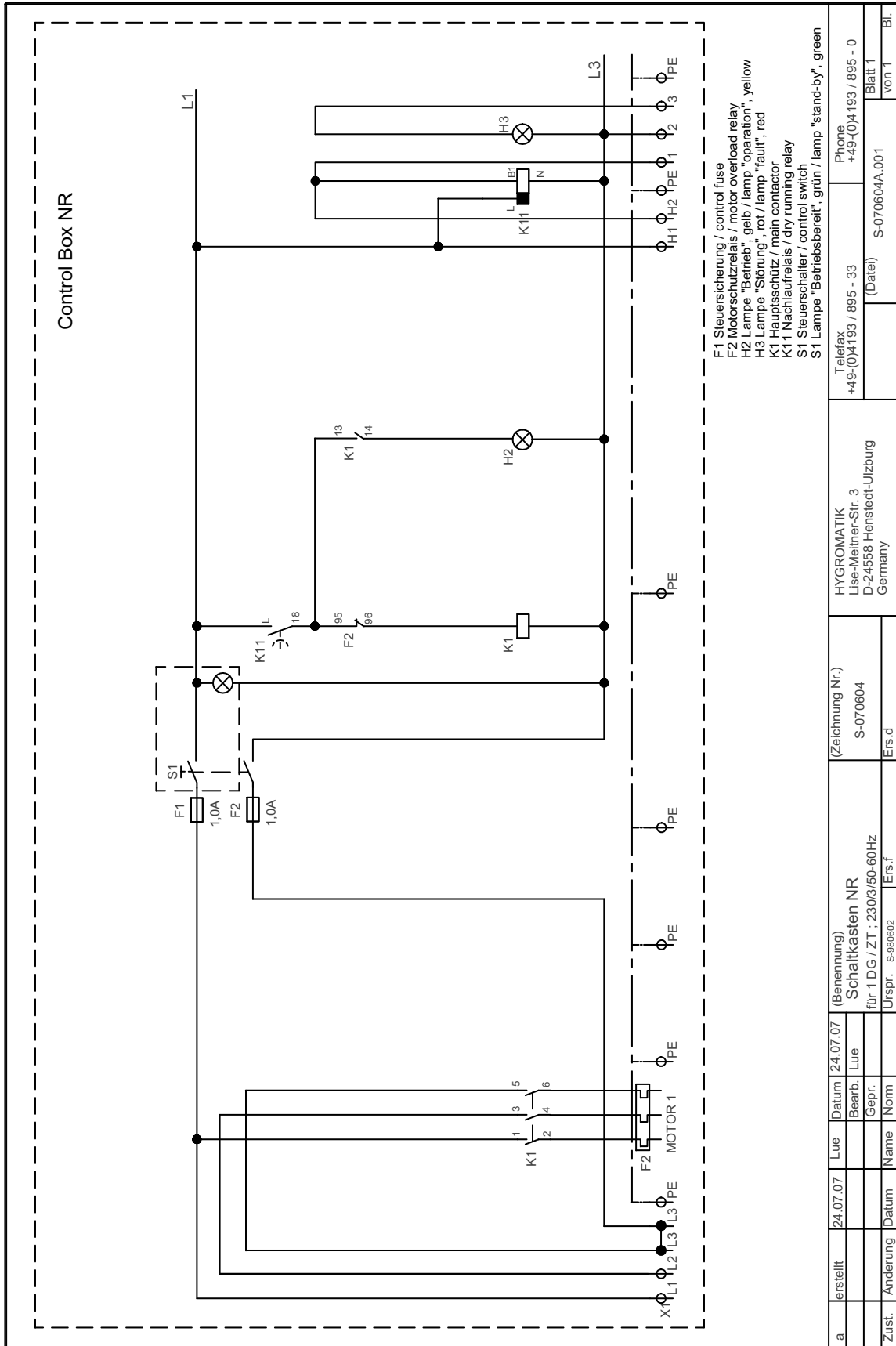

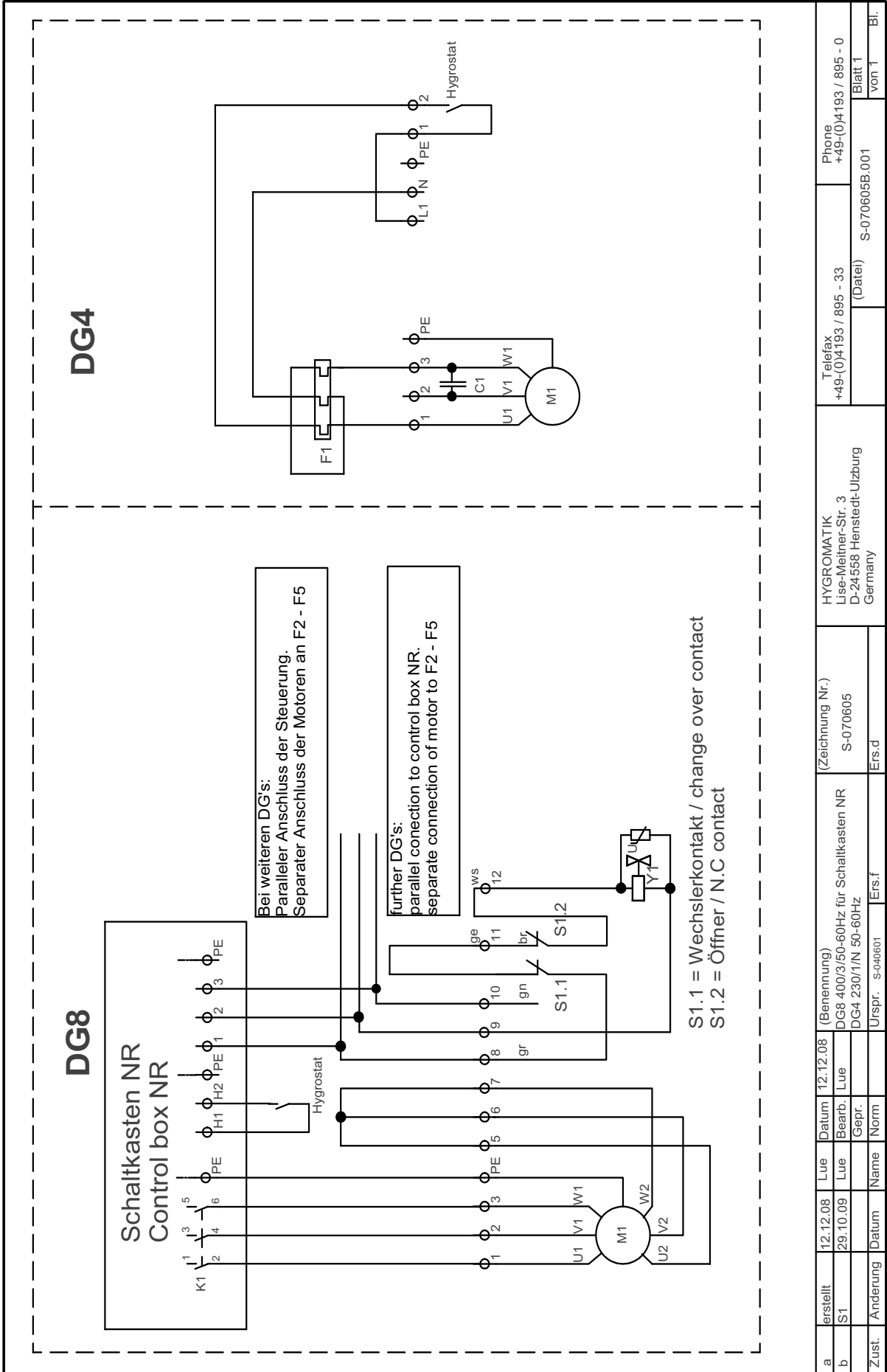

a	erstellt	12.12.08	Lue	Datum	12.12.08	(Benennung)	(Zeichnung Nr.)	HYGROMATIK Lise-Meitner-Str. 3 D-24558 Henstedt-Ulzburg Germany	Telefax +49-(0)4193 / 895 - 33 (Datei)	S-070605B.001	Phone +49-(0)4193 / 895 - 0
b	S1	29.10.09	Lue	Bearb.	Lue	DG8 400/3/50-60Hz für Schaltkasten NR	S-070605				
Zust.	Anderung	Datum	Name	Gepr.	Norm	DG4.230/1/N 50-60Hz	Ers.f				
						Urspr. S-040601	Ers.d				
											Blatt 1 von 1

13. Spare Parts

DG		Part Nr.	Description
4	8		
			Cabinet
	1	E-8101002	Motor hood
1		E-8101023	Air guidance hood
	1	E-8101006	Air guidance hood
1		E-8101024	Fan impeller
1		E-8101025	Guard grille for fan impeller
	1	E-8101011	Guard grille for fan impeller, compl. with fixing screws
1		B-8101026	Water pan with safety overflow 1/2"
	1	B-8101014	Water pan with safety overflow 1/2"
			Drive motor and accessories
1		B-8201023	Drive motor 230 V/3/N ~ 50 Hz, with capacitor, A- and B-side shaft
	1	E-8201022	Drive motor 230/400 V/3/N ~ 50 Hz, A- and B-side shaft
1		E-8201024	Capacitor for AC operation 220 V/1/N ~ 50 Hz
4		E-8201027	Fixing screws for motor, with U-washers and lock washers
	4	E-8201005	Fixing screws for motor, with U-washers and lock washers
1		E-8201023	V-Ring for motor shaft A-side
1		E-8201043	V-Ring for motor shaft B-side
	2	E-8201006	V-Ring for motor shaft A-side and B-side
1	1	B-8201018	Terminal box, 12-poles, compl. with fixing screws
	6	E-8201019	Plug sockets for cable bushings
			Level control system and electr. safety overflow guard
	1	E-8301002	Two step control switch
	1	B-8301003	Solenoid valve 1 with holder - water inlet with built-in strainer
1		B-8301007	Mechanical float valve up to 6 bar, compl. with nut
1		B-8301008	Connecting union R 3/8" - pipe fitting ø6
	1	B-8301009	Solenoid valve - water inlet or electr. safety overflow guard, without inlet fitting
	1	E-8301010	Holder for solenoid valve
	1	E-8902013	Coil for solenoid valve, 230V
	1	E-8301037	Drain fitting
			Water feed and atomizer components
1		E-8401009	Water feed cone
	1	E-8401003	Water feed cone
1		E-8401010	Atomizer disc
	1	E-8401004	Atomizer disc
1		E-8401012	Baffle grid
	1	E-8401007	Baffle grid
2		E-8401011	Nuts and washers for fixing atomizer disc
	2	E-8401006	Nuts and washers for fixing atomizer disc
2		E-8401014	U-washer d=8,4 mm
	2	E-8401013	U-washer d=13 mm

DG			
4	8	Part Nr.	Description
Mechanical parts, hoses, screws, seals			
1	1	B-8501001	Flexible water feed pipe ass. (water line - solenoid valve) with connecting union
	1	B-8501002	Connecting line, solenoid valve 1 - solenoid valve 2, only for electr. safety overflow
	1	B-8501003	Water hose, solenoid valve - water pan, for water feed
1		E-8501020	Motor base plate, plastic
	1	E-8501004	Motor base plate, plastic
	1	E-8501006	Lower base plate for clamping baffle grid
3		E-8501021	Studs M8x145
	4	E-8501009	Studs M10x230
4		E-8501052	Eyebolts M8
	4	E-8501010	Eyebolts M10
3		B-8501022	Spacers, motor hood - air guidance hood
	4	B-8501011	Spacers, motor hood - air guidance hood
9		E-8501023	Washers, plastic, hard, d=8.5 mm
	16	E-8501012	Washers, plastic, hard, d=10.5 mm
12		E-2206057	Studs, M8
	16	E-2207009	Studs, M10
12		E-8501025	Washers, soft, as water pan seals
	16	E-8501014	Washers, soft, as water pan seals
3		E-8501026	Tommy screws for fixing water pan
	4	E-8501015	Tommy screws for fixing water pan
3		B-8501027	Suspension chains with carabiner
	4	B-8501018	Suspension chains with carabiner
3	4	E-8501046	Carabiner
1	1	B-8501017	Overflow connection assembly, 1/2", as hose nozzle
Control box and hygrostats			
	1	B-8601021	Control box NR with dry-run relais 400V/3
	1	B-8601023	Control box NR with dry-run relais 230/3
	1	B-8601011	Motor overload protector 1 - 1,6 A
1	1	B-8601010	Motor overload protector 0,63 - 1,0 A
		E-0611001	Room hygrosstat HG-Mini
		E-0611100	Duct sensor HG80

14. Technical data

Type HygroMatik		DG4 with air circulation	DG8 with air circulation
humidifying capacity	[kg/h]	4	8
effective volume*	[m ³]	400	1200
circulation air volume	[m ³ /h]	350	600
motor power rating	[kW]	0,14	0,25
power supply**	V/50Hz/3/N	230	-
	nominal current A	0,65	-
	V/50Hz/3/N	-	360 - 420
	nominal current A	-	0,77
	V/50Hz/3/N	-	210 - 240
	nominal current A	-	1,3
height	[mm]	540	620
diameter		280	390
operating water volume	[l]	0,5	0,5
max. water pressure	[kPa]	600	600
water connection:			
feed pipe		R 1/4"	R 1/4"
safety overflow		R 1/2"	R 1/2"
electric		-	Yes
safety water supply			
weight	[kg]	4,5	15,0
operation weight	[kg]	5,0	15,5
fuse protection	[A]	1 x 6	3 x 6
electric power	[kW]	0,138	0,167
safety class		1	1
IP protection class		IP24	IP24

* effective volume depends greatly on required room humidity** special voltage on request



HYGROMATIK®

Lise-Meitner-Str.3 • D-24558 Henstedt-Ulzburg
Phone +49(0)4193/ 895-0 • Fax -33
eMail hy@hygromatik.de • www.hygromatik.com
A member of the **spirax**/**sarco** Group