

■ Assembly and operating instructions

REMKO SLE series
Pool dehumidifiers

SLE 20



Contents

<i>Air dehumidification</i>	4-6
<i>Safety notes</i>	6
<i>Unit description</i>	7
<i>Set-up</i>	8
<i>Commissioning</i>	9
<i>Shutdown</i>	10
<i>Care and maintenance</i>	10
<i>Troubleshooting</i>	11
<i>Electrical wiring diagrams</i>	12
<i>Diagram, cooling cycle</i>	12
<i>Exploded view of the condensate tank</i>	13
<i>Spare parts list for the condensate tank</i>	13
<i>Exploded view of the SLE 20</i>	14
<i>Spare parts list for the SLE 20</i>	15
<i>Maintenance protocol</i>	16
<i>Intended use</i>	17
<i>Customer service and guarantee</i>	17
<i>Environmental protection and recycling</i>	17
<i>Unit dimensions</i>	18
<i>Technical data</i>	19



Carefully read this operating manual prior to commissioning / using the units!

This operating manual is a translation of the German original.

This manual is an integral part of the unit and must always be kept in the vicinity of the installation location or on the unit itself.

Subject to modifications; no liability accepted for errors or misprints!

REMKO SLE series

Air dehumidification

The correlations occurring when air is dehumidified are based on physical laws.

These are depicted here in graphical form in order to provide you with a brief overview of the principles of air dehumidification.

The use of REMKO air dehumidifiers

- Even if windows and doors are well insulated, water and moisture are still capable of penetrating thick concrete walls.
- The water required for setting in the production of concrete, mortar and plaster etc. may only be diffused after 1-2 months.
- Even moisture trapped in the masonry after high-water or a flood is released very slowly.
- The same is also true of moisture contained in stored materials for example.

The moisture (water vapour) released from parts of a building or materials is absorbed by the surrounding air. As a result, the moisture content increases, which ultimately gives rise to corrosion, mould, rot, peeling of paint and other unwanted damage.

By way of example, the diagram shows the corrosion rate of metal in different levels of humidity.

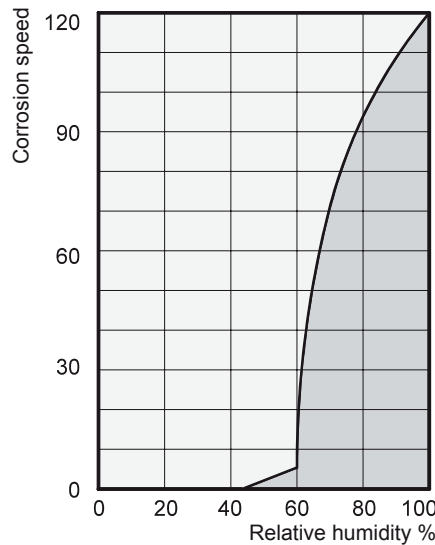

It is evident that the corrosion rate below 50 % relative humidity (RH) is low, and below 40 % is negligible.

The corrosion rate increases significantly above 60 % RH. This threshold for damage as the result of humidity also applies to other materials, such as powdery substances, packaging, wood and electronic units.

Buildings may be dried in a variety of ways:

1. By heating and air exchange:

The air in the room is heated in order for moisture to be removed and then this air is fed outside. All of the energy that is involved is lost together with the moist air that is released.

2. By air dehumidification:

The moist air that is present within an enclosed space is continuously dehumidified according to the condensation principle.

With regard to energy consumption, air dehumidification has one distinct advantage:

Energy expenditure is limited exclusively to the air volumes present. The mechanical heat that is released by the dehumidification process is fed back into the room.

Under normal use, the air dehumidifier uses approximately 25 % of the energy that is required for the “heating and ventilating” principle.

Relative air humidity

Our ambient air is a gaseous mixture which always contains a certain volume of water in the form of water vapour. This volume of water is specified in g per kg of dry air (absolute moisture content).

1 m³ of air weighs approx. 1.2 kg at 20 °C

Depending on the temperature, each kg of air is only capable of absorbing a certain volume of water vapour. Once this capacity has been reached, the air is referred to as “saturated” and has a relative humidity (RH) of 100 %.

Relative humidity is understood to mean the ratio between the current quantity of water vapour in the air and the maximum possible quantity of water vapour at the same temperature.

The ability of the air to absorb water vapour increases as the temperature rises. I.e. the maximum possible (absolute) water content becomes greater as the temperature rises.

Temp. °C	Water vapour content in g/m ³ at humidity of			
	40 %	60 %	80 %	100 %
-5	1.3	1.9	2.6	3.3
+10	3.8	5.6	7.5	9.4
+15	5.1	7.7	10.2	12.8
+20	6.9	10.4	13.8	17.3
+25	9.2	13.8	18.4	23.0
+30	12.9	18.2	24.3	30.3

The condensation of water vapour

Because the capacity for the maximum possible volume of water vapour increases as the air is heated, the volume of water vapour contained remains constant and so relative humidity falls.

In contrast, because the capacity for the maximum possible volume of water vapour decreases as the air is cooled, the volume of water vapour contained remains constant and so relative humidity increases.

If the temperature continues to fall, the capacity for the maximum possible volume of water vapour is reduced so much so that it is ultimately equal to the volume of water vapour contained in the air. This temperature is referred to as the dew point. If the air is cooled to below the dew point, the volume of water vapour in the air will become greater than the maximum possible volume of water vapour. At this point, the water vapour begins to precipitate. It then condenses to water. Humidity is then removed from the air.

Drying materials

Building materials and structures are capable of absorbing considerable volumes of water, such as brick 90-190 l/m³, heavy concrete 140-190 l/m³ and limestone 180-270 l/m³.

The drying of moist materials such as masonry is effected as follows:

- The moisture moves from the inside of the material to its surface

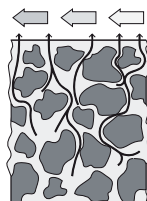

- Evaporation occurs on the surface = transfer of water vapour to the ambient air

- The air containing water vapour is constantly circulated through the REMKO air dehumidifier. The air is dehumidified and, slightly heated, leaves the unit in order to re-absorb water vapour

- In this way, the moisture contained in the material is reduced gradually
The material is dried!

The accumulated condensate is collected in the unit and drained off from there.

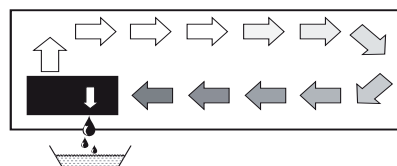

As it flows through or over the evaporator, the air stream is cooled to dew point. The water vapour condenses, and is collected in a condensate trap from where it is drained off.

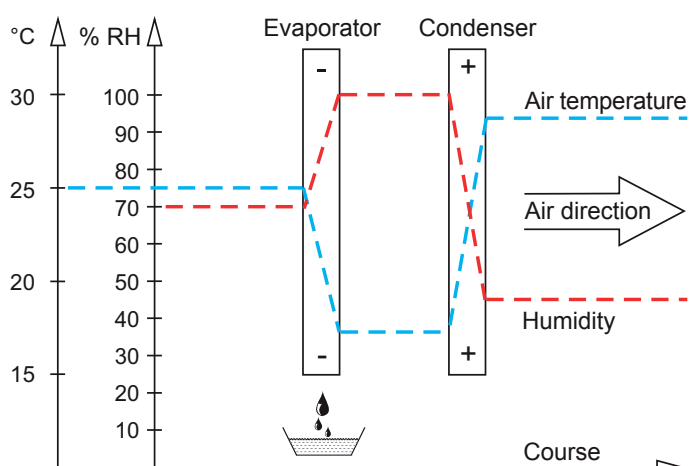

Examples of condensation include steamed-up window panes in winter, or the moisture on the outside of a cold drinks bottle.



As the relative humidity of the air increases, so too does the dew point, making it easier for the temperature to fall below it.

REMKO SLE series

Condensation heat

The Energy transferred to the air from the condenser consists of:

1. The amount of heat derived beforehand in the evaporator.
2. The electrical drive energy.
3. The condensation heat released by liquefying the water vapour.

Energy must be supplied when liquid is converted into a gas. This energy is designated as evaporation heat. It does not cause any increase in temperature, but is required to convert a liquid into a gas.

Conversely, energy is released when gas is liquefied, this is designated as condensation heat.

The amount of energy from evaporation heat and condensation heat is the same.

**For water, this is:
2250 kJ/kg (4.18 kJ = 1kcal)**

From this it is evident that the condensation of water vapour causes a large quantity of energy to be released.

If the moisture that is to be condensed is not introduced by evaporation in the room itself, but from outside, e.g. through ventilation, the condensation heat released contributes to the heating of the room.

When dehumidifying, a heat cycle is created, whereby heat is consumed for evaporation and released for condensation. When dehumidifying fed air, a larger contribution of heat is created, which manifests itself as a temperature increase.

Generally speaking, the time required for the drying process is not only dependent on the output of the unit, but is determined to a greater extent by the speed at which the material or building section loses its moisture.

Safety notes

The units have been subjected to extensive material, functional and quality inspections prior to delivery.

However, dangers can result from the units if they are used improperly or not as intended by untrained personnel.

The following notes must be observed in full:

- The units may not be installed or operated in explosive environments
- The units must not be installed or operated in atmospheres containing oil, sulphur or salt

- The units must not be exposed to direct jets of water
- An unobstructed air inlet and air outlet must be guaranteed at all times
- The air-inlet grill must always be kept free of dirt and loose objects
- The units must not be covered during operation
- Never stick foreign objects into the units
- All electrical cables on the outside of the units must be protected against damage (e.g. by animals etc.)
- The units are only permitted to be set up or installed in the intended position (upright)
- Unobstructed and frost-proof condensate drainage must be ensured
- The unit connections must always be established according to the applicable installation regulations

CAUTION

Work on the refrigerant system and on the electrical equipment must only be conducted by a specially-authorized specialist!

Unit description

The units have been designed for universal and straightforward air dehumidification.

Their compact dimensions allow them to be installed in many locations.

The units operate in accordance with the condensation principle and are equipped with a hermetically sealed refrigerant system, low-noise and low-maintenance fan and connection cable with plug.

The fully-automated electronic controller hot gas defrosting, an integrated hygrostat and connection ports for condensate drainage provided by the customer ensure continuous fault-free operation.

The units are reliable and conform to the fundamental health and safety requirements of the appropriate EU stipulations.

The units are used in all locations where dry air is a must and where economic consequential damage (such as that caused by mould) must be prevented.

The units may be used to dehumidify areas such as:

- Private swimming pools
- Spa areas
- Jacuzzi areas
- Fitness centres
- Storage rooms/archives
- Museums

Operating sequence

The operating switch and the integrated hygrostat are used to switch the units on and off. The green indicator light for “**Dehumidification**” at the top of the front plate illuminates indehumidification mode.

The fan extracts the moist room air through the suction openings integrated into the bottom of the front plate.

This air is fed through a filter, an evaporator and a condenser. Heat is removed from the room air on the cold *evaporator*. The air is then cooled to below dew point. The water vapour contained in the room air is then deposited as condensate or rime on the evaporator pipes.

On the *condenser* (heat exchanger), the cold and dehumidified air is warmed up again and discharged back into the room via the side outlet blower openings with a temperature increase of around 5 °C above the room temperature. The processed, dry air therefore continuously mixes with the room air.

Continuous circulation of the room air through the unit gradually reduces the relative humidity (% RH) in the room to the desired humidity level.

The hygrostat is set to 50 % RH in the factory.

Depending on the room air temperature and the relative humidity, condensed water will drip into the condensate trap and then through the integrated discharge nozzle into the condensate drain to be provided by the customer, either continuously or only during the defrosting phases.

Safety circuit:

If the temperature exceeds 55 °C on the condenser (e.g. due to a fan failure or a contaminated intake filter), the unit stops automatically to prevent an overload.

The unit restarts automatically after 45 minutes.

NOTE

In normal operation, the compressor always starts with a delay of around 45 seconds.

Schematic depiction of the workings of the SLE 20 air dehumidifier

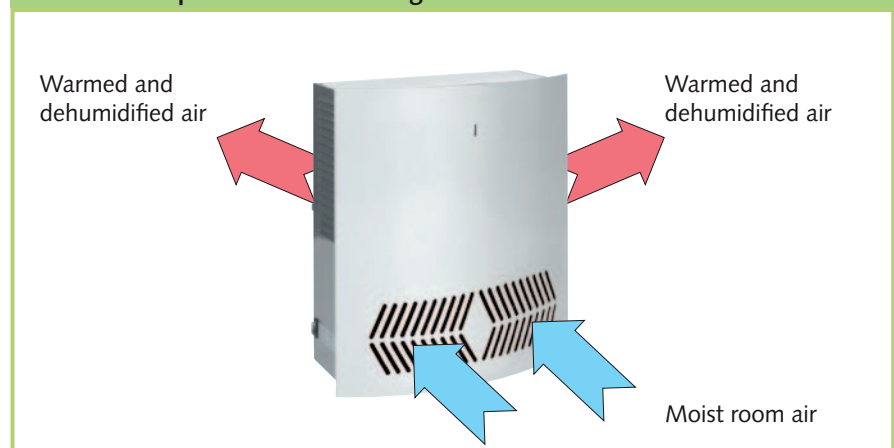

REMKO SLE series

Set-up

For optimum and safe use of the units, the following notes must be followed in full:

- The unit must be installed or set up in a suitable location according to the building conditions
- Mount the wall console provided securely to the wall using suitable fastening fixtures (not included)
- The unit must be mounted or set up upright to ensure that the condensate can drain freely
- The unit must be mounted or set up upright to ensure that air can be taken in and blown out freely
- Observe the minimum gaps between the unit and the ceiling and floor to ensure optimum unit operation
- The unit must never be set up in the immediate vicinity of heaters or other sources of heat
- The room being dehumidified must be closed to the neighbouring atmosphere
- Avoid having opened windows and doors etc., and avoid frequent entry to or exit from the room as much as possible
- In order to obtain optimum room air circulation through the dehumidifier, the supply and exhaust air openings must always remain free of dirt and any other hindrances

Electrical wiring

- The units are operated with 230 V/50 Hz alternating current
- The electrical connection is established via the supplied mains cable with earthed safety plug
- The electrical connection may only be established at a socket that is suitable for the space and unit performance



⚠ CAUTION

The unit connections must always be established according to the applicable installation regulations.

⚠ CAUTION

Careful and professional installation or assembly must be ensured.

💡 NOTE

Care must be taken to ensure that the air can enter through the front and exit through the sides without hindrance. For optimum operation, we recommend a distance of 100 mm around the unit.

⚠ CAUTION

*A cable tie is installed on the rear of the unit as a transport safeguard for the compressor. **This must be removed before installing the unit.***

Condensate water drain

The condensate water drain is located on the unit's base. Condensate drainage is connected to the discharge nozzle supplied (but not installed).

A solid or flexible ½" discharge connector can be installed on this.

- The discharge hose must always be laid at an incline of at least 2 % so that the water can flow unhindered from the drip tray
- If drainage is to be carried out through the wall, the relevant measures such as holes for correct condensate drainage must be taken before installing the unit
- See the diagram below for information on the location of the drainage connection

Location of the condensate discharge

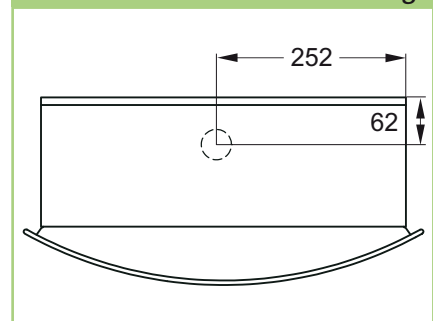

💡 NOTE

A separate condensate tank with integrated overflow protection is available as an accessory.

Additional condensate tank

In situations where natural condensate drainage is not possible or is very difficult, the unit can be equipped with an additional condensate tank.

The condensate tank is available as an accessory.

The condensate tank is installed directly below the unit, see the diagram below.

If the unit is used with a condensate tank, the dehumidifier switches off automatically when the tank is full.

An LED on the front plate illuminates red when the tank is full and must be emptied.

The condensate tank comprises the following parts:

- Condensate tank housing with magnetic switch to stop the water and cable connection to the board
- Condensate collection tank
- 4 fastening screws



Installing the condensate tank

- Attach the unit to the wall bracket provided
- After removing the 2 screws on the top of the unit, lift the front plate vertically upwards and then pull away from the unit horizontally
- Use 4 fastening screws to screw the condensate tank housing underneath the unit
- Guide the unit connection cable through the membrane sleeve on the base of the condensate tank housing

Access to the controller:

The electronic controller is located in a housing in the middle of the unit.

The controller is accessed by removing the 4 screws on the sides of the housing.

- Guide the cable for the magnetic switch through the membrane sleeve on the base of the unit and connect to terminals **13 and 14** on the control board
- Re-install the cover for the controller and the unit's front plate
- Insert the condensate tank into the condensate tank housing. Place the condensate tank so that the float points towards the magnetic switch

Commissioning

Before commissioning the unit or if local requirements dictate, the air-inlet grill and air-outlet grill must be checked for contamination.

After using the operating switch to switch on, the units work via an integrated hygostat that is set to 50 % RH (standard value for spas and indoor swimming pools).

If the room humidity is below 50 % RH, the unit does not start. If the relative humidity is above 50 %, the unit starts the dehumidification process automatically.

The front plate must be removed to make any required changes to the hygostat setting.

The hygostat is installed below the electronic controller.

Turn the rotary knob clockwise: **lower air humidity**, turn it anticlockwise: **higher air humidity**.

In order to prevent damage to the condenser, the units are equipped with a mechanism that prevents the compressor being immediately switched back on after it is switched off.

NOTE

Restart protection!

The compressor does not switch back on until after a waiting time of approx. 45 seconds!

NOTE

A contaminated grille or filter must be cleaned or replaced immediately.

REMKO SLE series

Care and maintenance

Operation display LED

LED on the front panel illuminates:

Green= Unit dehumidifying

Red = The water tank that is inserted (accessory) is full and must be emptied

Defrosting

If the room temperature is below 20 °C, the evaporator will start to ice up after a short time.

If the evaporator probe registers a temperature of less than 5 °C on the evaporator surface, the unit only continues to run in dehumidification mode for a further 44 minutes.

After this time has elapsed, the fan stops and a hot gas injector is used to defrost the evaporator surface. When the evaporator probe registers a temperature higher than 5 °C, the fan switches on again and dehumidification mode starts again.

Shutdown

- Move the operating switch to the "0" (off) position
- If the units are inactive for long periods, disconnect them from the mains power supply
- If installed, the condensate tank must be emptied and rinsed with clean water
Beware of dripping condensate!



NOTE

Regular care and maintenance is fundamental to a long service life and fault-free operation of the unit.

All moving parts have a low-maintenance permanent coat of lubricant. The refrigerant system is designed as a hermetically sealed system and may only be repaired by a specialist.

- Observe the regular care and maintenance intervals
- In accordance with the operating conditions, the units must, if necessary, be checked at least yearly by a specialist to ensure that they are in a condition that is safe to use
- Keep the units free of dust and other debris
- If the unit is contaminated, use suitable agents to clean it carefully and thoroughly
- If the evaporator's pipes are heavily soiled, they can be cleaned carefully with soapy water
- Never subject to direct jets of water
e.g. pressure washers etc.
- Never use abrasive or solvent-based cleaners
- Use only suitable cleaners, even for heavy contamination

Cleaning the suction filter

Check the suction filter at regular intervals and clean if necessary. The filter is secured in a bracket behind the intake openings.



CAUTION

Check the intake and outlet openings, as well as filters, regularly for contamination.

- Light filter contamination can be remedied with careful blowing or suction
- Heavier contamination may be remedied by rinsing the filter in a lukewarm (max. 40 °C) soap solution. Finally, always rinse the filter carefully with clear water and allow to dry
- Before refitting the filter, ensure that its fully dry and that no damage has been sustained
- The units may only be operated with the filter in place



NOTE

*Heavily contaminated filters must be replaced with new parts.
Only original replacement parts may be used.*

Cleaning the condensate water collection tray

To ensure that the condensate water that accumulates can always drain freely, the collection tray for the condensate and the drain must be cleaned regularly.

Troubleshooting

The units are manufactured using state-of-the-art production methods and tested several times to verify their correct function. However, if a functional fault should occur, the unit should first be checked in accordance with the following list.

The unit does not start

- Check the setting of the operating switch
- Check the power supply and the power fuse provided by the customer -230V/1~/50 Hz-
- Check the power plug and the cable for damage
- If a condensate tank is installed, check how full it is and that it is positioned correctly
- Check the integrated hygrostat. Set the hygrostat to a lower relative humidity level (turn the adjustment knob on the far right). If the unit does not start up, check the integrated hygrostat for faults

The unit switches off automatically, does not restart for 45 minutes and switches off again after a short time

- Does the fan run when the unit restarts after 45 minutes?
- Is the condenser surface contaminated?
- Is the suction filter contaminated?
- Is the ambient temperature over 30 °C?
- Are the intake and outlet openings clear?

NOTE

A contaminated grille or filter must be cleaned or replaced immediately.

The unit runs but does not form any condensate

- Check the room temperature. The operating range of the unit is between 3 °C and 30 °C
- Check the air humidity, at least 40 % RH is required
- Check the suction filter for contamination and clean or replace if necessary
- Check the evaporator and condenser for contamination and clean if necessary
- Check the evaporator for ice or rime formation. If ice has formed, check the functionality of the automatic defrost and the temperature sensor

The red indicator light (malfunction) also illuminates if the condensate tank is empty

- Check whether the water tank's float can move freely or whether it is damaged

The condensate tank is full but the unit does not switch off automatically

- Check whether the condensate tank is installed correctly in the housing and whether the float is positioned towards the magnetic switch
- Check whether the water tank's float can move freely or whether it is damaged

NOTE

If the unit fails to function correctly after the checks have been carried out, contact an authorised specialist.

CAUTION

Work on the refrigerant system and on the electrical equipment must only be conducted by a specially-authorized specialist!

REMKO SLE series

Electrical wiring diagram

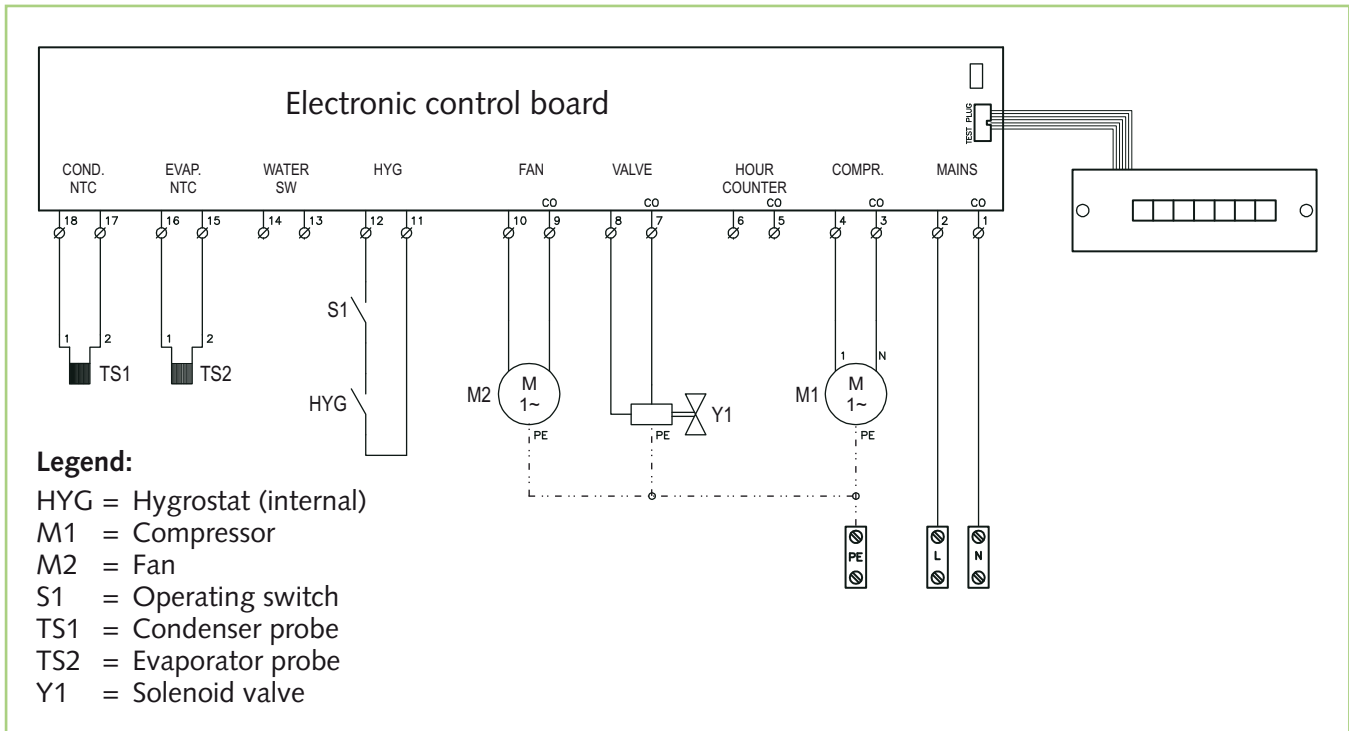

Cooling cycle

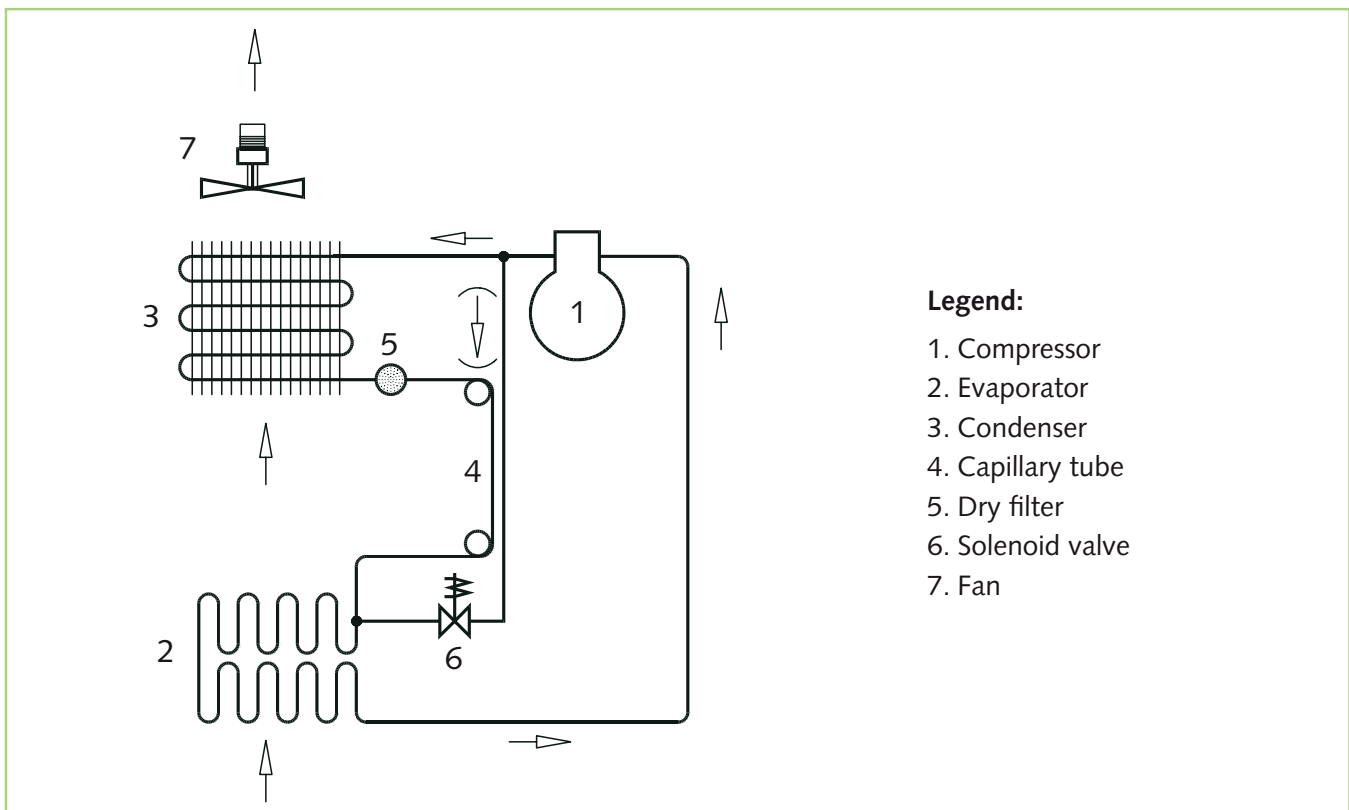

We reserve the right to modify the dimensions and design as part of the ongoing technical development process.

Condensate tank (accessory)

Additional condensate tank

In situations where natural condensate drainage is not possible or is very difficult, the unit can be equipped with an additional condensate tank.

The condensate tank is installed directly below the unit.

If the unit is used with a condensate tank, the dehumidifier switches off automatically when the tank is full.

An LED on the front plate illuminates red when the tank is full and must be emptied.

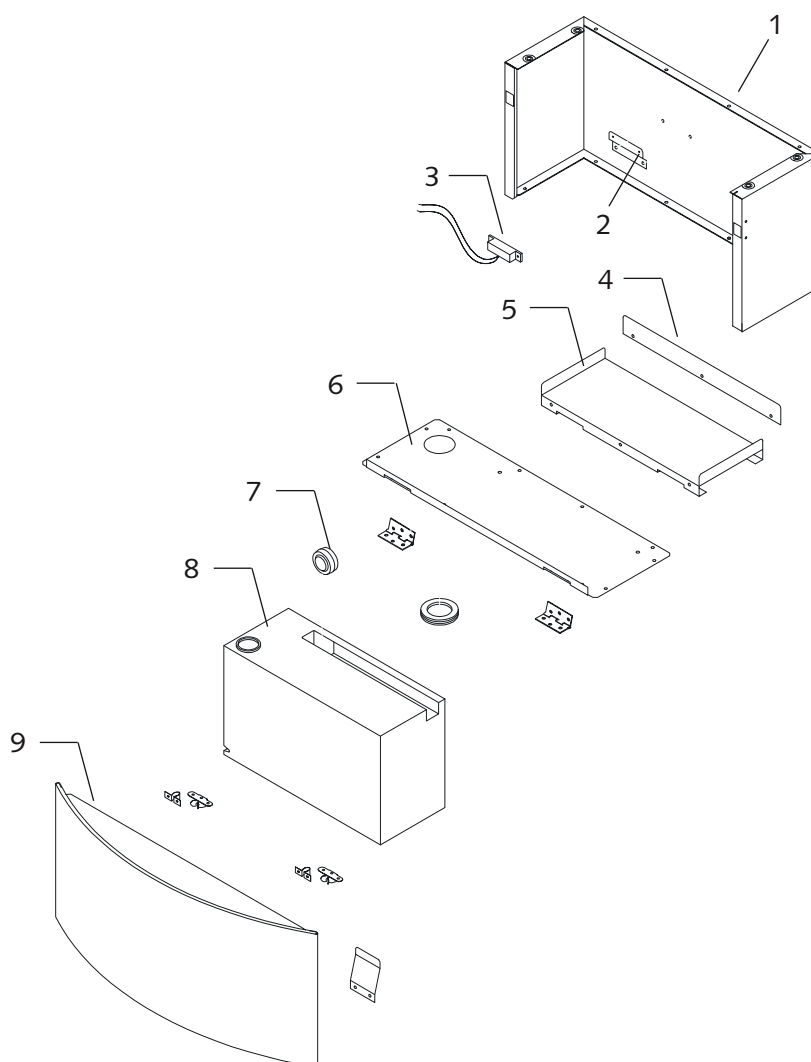

NOTE

The condensate tank has a capacity of 6 litres.
The automatic shut-down occurs when the level reaches 5 litres.

Spare parts list

No.	Designation	EDP
1	Housing	1109131
2	Bracket for magnetic switch	1109132
3	Magnetic switch	1109133
4	Stop rail	1109134
5	Condensate tank bracket	1109135
6	Complete housing base	1109136
7	Float	1109139
8	Condensate container cpl.	1109140
9	Front panel	1109142

REMKO SLE series

Exploded view of the SLE 20

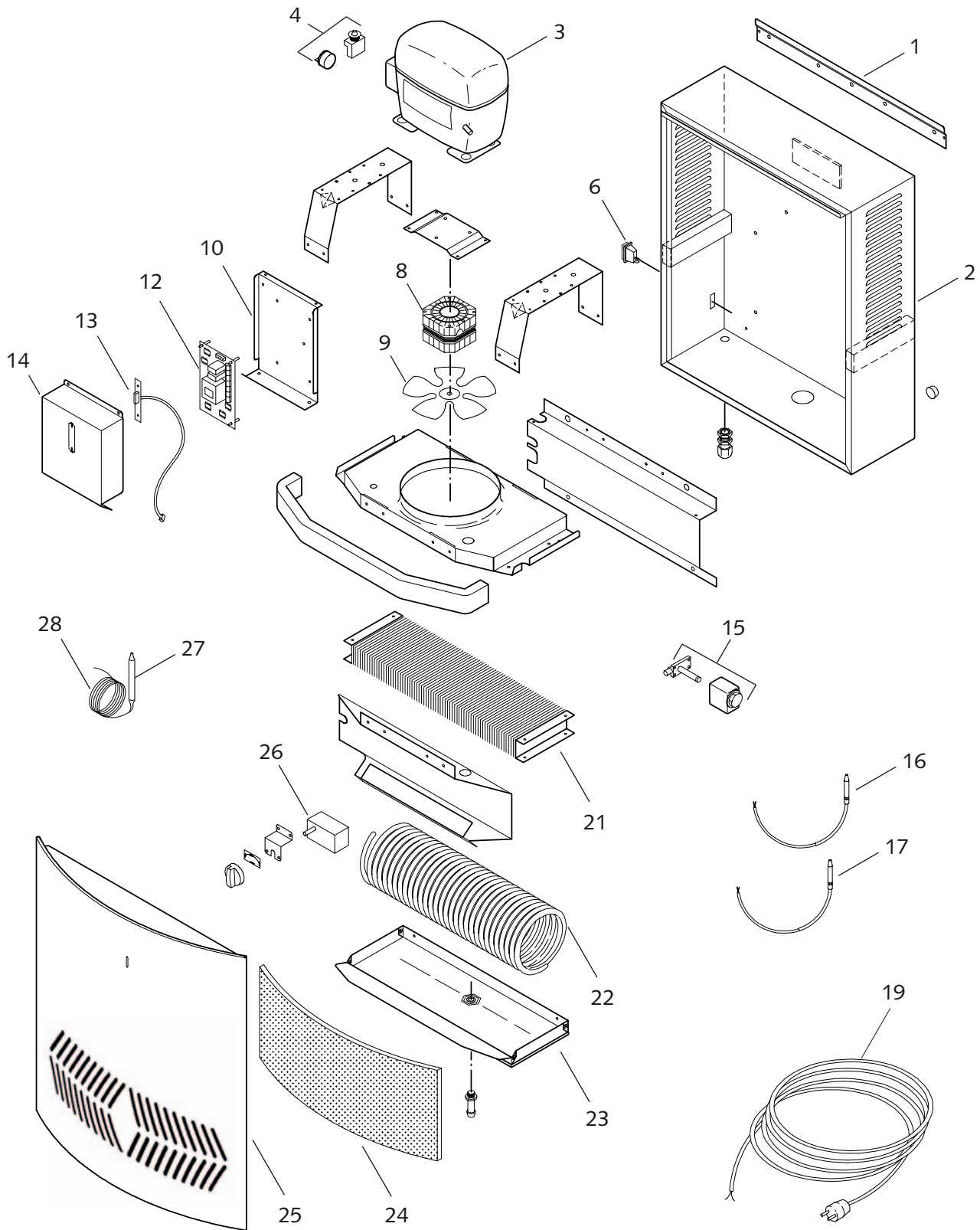

Spare parts list

No.	Designation	EDP
1	Wall-mounted bracket	1109100
2	Complete housing	1109101
3	Compressor, cpl.	1109102
4	Complete start relay	1109103
6	Operating switch	1109113
8	Fan motor	1109105
9	Fan blade	1109106
12	Control board	1109107
13	LED board	1109108
14	Electronics cover	1109109
15	Solenoid valve, cpl.	1109110
16	NTC condenser probe	1109112
17	NTC evaporator probe (metal)	1109111
19	Mains cable with plug	1109124
21	Condenser	1109114
22	Evaporator	1109121
23	Complete condensate tray	1109122
24	Suction filter	1109127
25	Front plate	1109126
26	Complete hygrostat	1109115
27	Dry filter	1109119
28	Capillary tube	1109120

REMKO SLE series



Maintenance protocol

Unit type: Unit number:

	1	2	3	4	5	6	7	8	9	10	11	12	13	14	15	16	17	18	19	20
Unit cleaned - outside -																				
Unit cleaned - inside -																				
Condenser cleaned																				
Evaporator cleaned																				
Fan function checked																				
Unit checked for damage																				
Safety devices checked																				
All fastening screws checked																				
Electrical safety check																				
Test run																				

Comments:

.....

.....

.....

.....

1. Date: Signature	2. Date: Signature	3. Date: Signature	4. Date: Signature	5. Date: Signature
6. Date: Signature	7. Date: Signature	8. Date: Signature	9. Date: Signature	10. Date: Signature
11. Date: Signature	12. Date: Signature	13. Date: Signature	14. Date: Signature	15. Date: Signature
16. Date: Signature	17. Date: Signature	18. Date: Signature	19. Date: Signature	20. Date: Signature

Unit to be maintained only by authorised specialists in accordance with the statutory regulations.

Intended use

The units are designed exclusively for dehumidification purposes on the basis of their structural design and equipment.

A failure to observe the manufacturer's specifications, the respective local legal requirements or arbitrary alterations to the units, exempts the manufacturer from liability for resulting damage.

NOTE

Operation other than the types listed in this operating manual is prohibited. With non-observance, any manufacturer liability or guarantee claims are voided.

CAUTION

*Copyright
The redistribution, even in part, or the use of this documentation for purposes other than intended is strictly prohibited without the written authorisation of **REMKO GmbH & Co. KG.***

Customer service and guarantee

As a prerequisite for any guarantee claims to be considered, it is essential that the ordering party or their representative complete and return the "**Certificate of guarantee**" to REMKO GmbH & Co. KG at the time when the units are purchased and commissioned.

The units were tested at the factory several times to verify their correct function.

However, if malfunctions should arise that cannot be remedied by the operator with the assistance of the troubleshooting section, please contact your specialist dealer or contractual partner.

NOTE

Setting and maintenance work may only be carried out by authorised and qualified technicians.

Important information concerning recycling

The units are operated with environmentally-friendly and ozone-neutral R134A refrigerant. The mixture of refrigerant and oil within the unit must be disposed of properly in accordance with the statutory or locally-applicable regulations.



Environmental protection and recycling

Disposal of packaging

When disposing of packaging material, please consider our environment.

Our units are carefully packed and delivered in stable transport packaging and, if applicable, on a wooden pallet.

The packaging materials are environmentally-friendly and can be recycled.

By recycling packaging materials, you make a valuable contribution to the reduction of waste and conservation of raw materials. **Therefore, only dispose of packaging material at appropriate collection points.**

Disposal of the old unit

The manufacturing process for the units is subject to continuous quality control.

Only high-grade materials are processed, the majority of which are recyclable.

You also contribute to environmental protection by ensuring that your old equipment is only disposed of in an environment friendly manner.

Therefore, only bring the old unit to an authorised recycling business or to an appropriate collection point.



REMKO SLE series

Unit dimensions

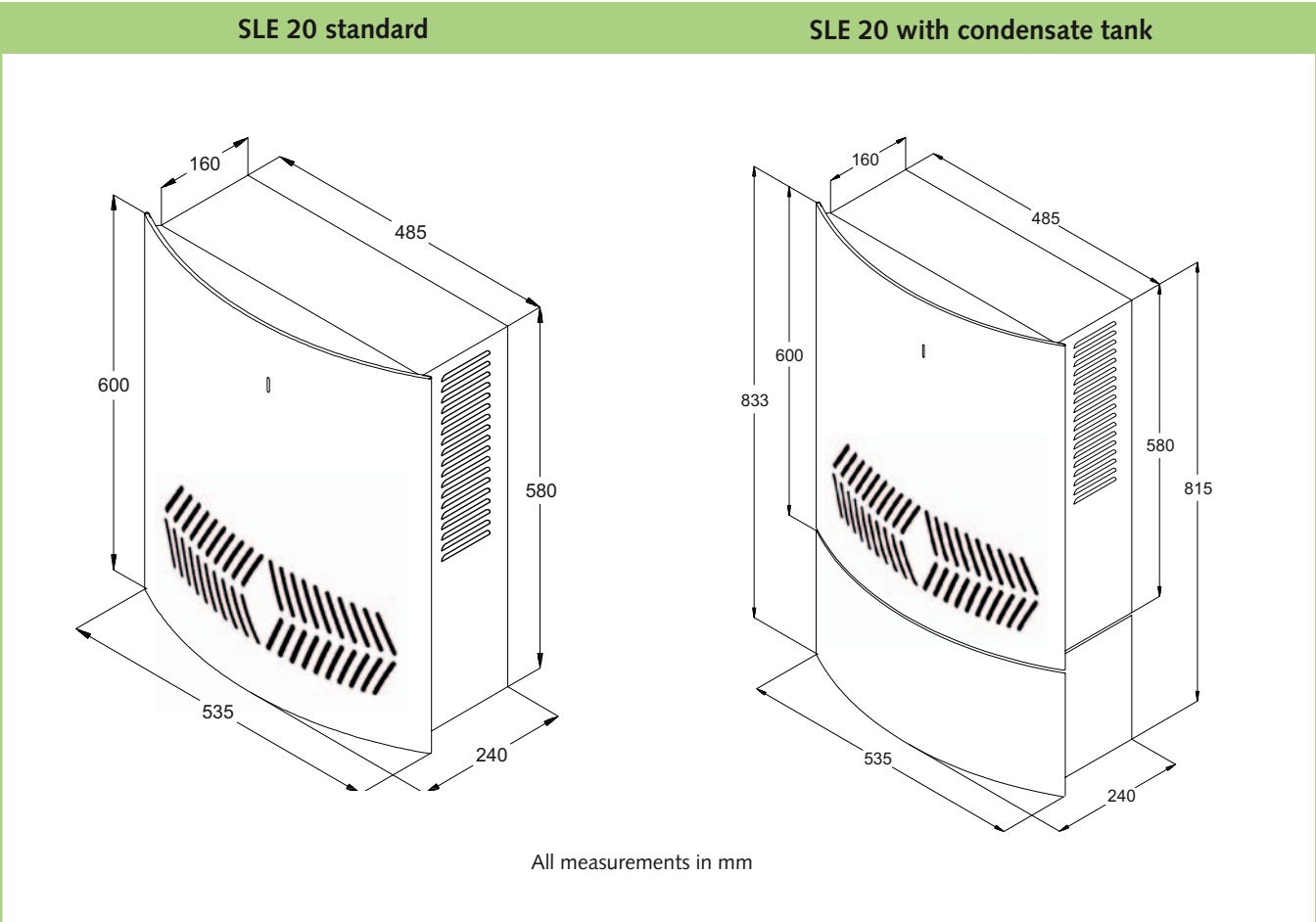

We reserve the right to modify the dimensions and design as part of the ongoing technical development process.

Technical data

Series	SLE 20	
Daily dehumidification capacity at 30 °C and 80 % RH	Litres/day	10.5
Daily dehumidification capacity at 30 °C and 60% RH	Litres/day	7.5
Operational temperature range	°C	3-30
Usable humidity range	% RH	40-100
Air volume	m ³ /h	220
Refrigerant ¹⁾		R134a
Refrigerant quantity	g	190
Power supply	V/Hz	230/1~/50
Max. rated current consumption	A	2.1
Max. power consumption	kW	0.39
Sound pressure level L _{pA} 1m ²⁾	dB (A)	46
Depth	mm	240
Width	mm	535
Height	mm	600
Weight	kg	28
EDP		615200

¹⁾ Contains greenhouse gas according to Kyoto protocol

²⁾ Noise level measurement DIN 45635 - 13 - KL 3

Capacity diagram

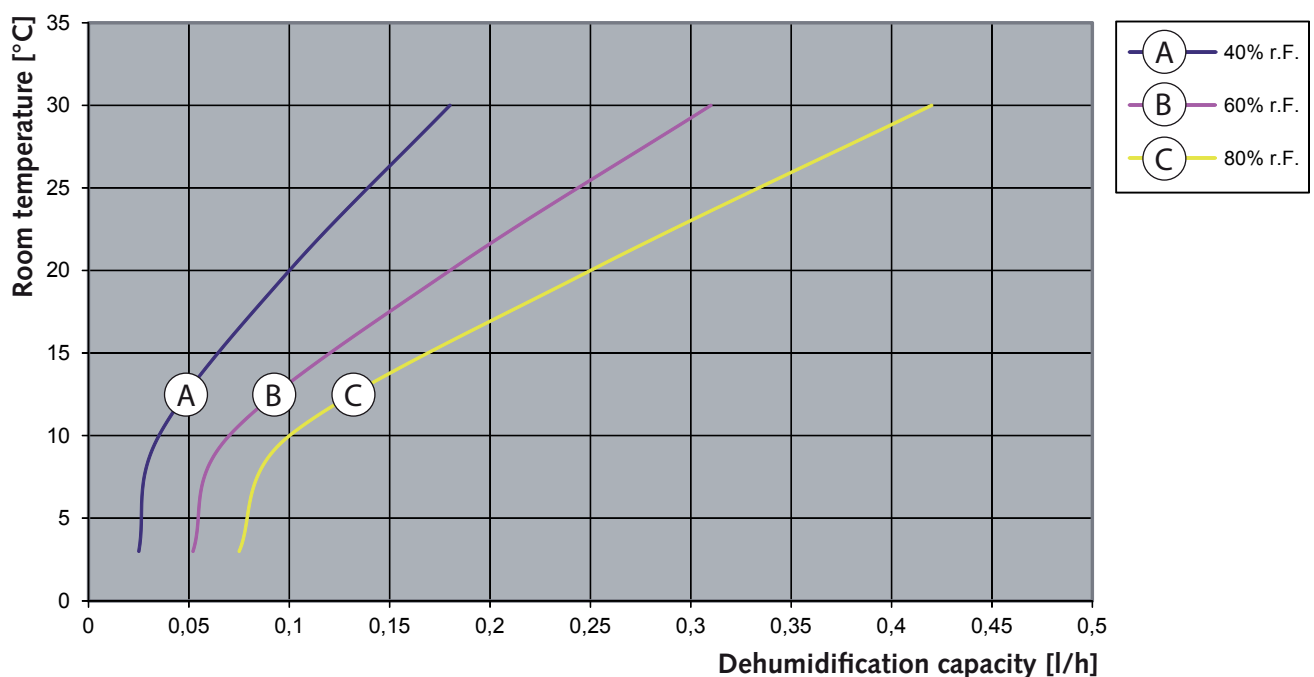

REMKO INTERNATIONAL

*... and also right in your neighbourhood!
Take advantage of our experience and advice*



REMKO GmbH & Co. KG **Air conditioning and heating technology**

Im Seelenkamp 12 D-32791 Lage
Postfach 1827 D-32777 Lage
Telephone +49 5232 606-0
Fax +49 5232 606-260
E-mail info@remko.de
Internet www.remko.de

Consulting

Thanks to intensive training, our consultants are always completely up-to-date when it comes to technical expertise. This has given us the reputation of being more than just an excellent, reliable supplier: REMKO, a partner who helps to solve problems.

Sales

REMKO offers not just a well established sales network both nationally and internationally, but also has exceptionally highly-qualified sales specialists. REMKO employees in the field are more than just sales people: above all, they must be advisers to our customers in air conditioning and heating technology.

Customer service

Our units operate precisely and reliably. However, in the event of a malfunction REMKO customer service is quickly on the scene. Our extensive network of experienced dealers guarantees quick and reliable service.

