

# ■ Operating and installation instructions

## **REMKO SLN series Swimming pool dehumidifiers**

SLE 45, SLE 65, SLE 85





## Contents

<i>Safety notes</i>	4
<i>Air dehumidification</i>	5-7
<i>Testing the water quality</i>	8
<i>Unit description</i>	9
<i>Set-up</i>	10-13
<i>Commissioning</i>	14-15
<i>Unit function</i>	16
<i>Wireless remote control</i>	17-19
<i>LED remote control</i>	20
<i>Care and maintenance</i>	21
<i>Troubleshooting</i>	22
<i>Fault and information messages</i>	23
<i>Diagram, cooling cycle</i>	24
<i>Electrical wiring diagram</i>	25
<i>Intended use</i>	26
<i>Customer service and guarantee</i>	26
<i>Environmental protection and recycling</i>	26
<i>Exploded view of the unit</i>	28
<i>Spare parts list</i>	29
<i>RS-485 interface</i>	30-32
<i>USB interface</i>	33
<i>Maintenance log</i>	34
<i>Technical data</i>	35-37



**Carefully read this Operating Manual prior to commissioning/ using the units.**

**This operating manual is a translation of the German original.**

**These instructions are an integral part of the unit and must always be kept in the vicinity of the installation location or on the unit itself.**

*Subject to modifications; no liability accepted for errors or misprints!*

# REMKO SLE series

## Safety notes

The units have been subjected to extensive material, functional and quality inspections prior to delivery.

However, dangers can result from the units if they are used improperly or not as intended by untrained personnel.

### The following notes must be observed in full:

- The units may not be installed or operated in explosive environments
- The units must not be installed or operated in atmospheres containing oil, sulphur or salt
- The units must not be exposed to direct jets of water
- An unobstructed air inlet and air outlet must be guaranteed at all times
- The air-inlet grill must always be kept free of dirt and loose objects
- The units must not be covered during operation
- Never stick foreign objects into the units
- All electrical cables on the outside of the units must be protected against damage (e.g. by animals etc.)
- The units are only permitted to be set up or installed in the intended position (upright)
- Unobstructed and frost-proof condensate drainage must be ensured at all times
- The unit connections must always be established according to the applicable installation regulations

### CAUTION

*The units must be set up and installed in such a way that they are easily accessible for monitoring, repair and maintenance work.*

## Air dehumidification

The correlations occurring when air is dehumidified are based on physical laws.

These are depicted here in graphical form in order to provide you with a brief overview of the principles of air dehumidification.

### The use of REMKO air dehumidifiers

- Even if windows and doors are well insulated, water and moisture are still capable of penetrating thick concrete walls.
- The water required for setting in the production of concrete, mortar and plaster etc. may only be diffused after 1-2 months.
- Even moisture trapped in the masonry after high-water or a flood is released very slowly.
- The same is also true of moisture contained in stored materials for example.

The moisture (water vapour) released from parts of a building or materials is absorbed by the surrounding air. As a result, the moisture content increases, which ultimately gives rise to corrosion, mould, rot, peeling of paint and other unwanted damage.

By way of example, the diagram shows the corrosion rate of metal in different levels of humidity.

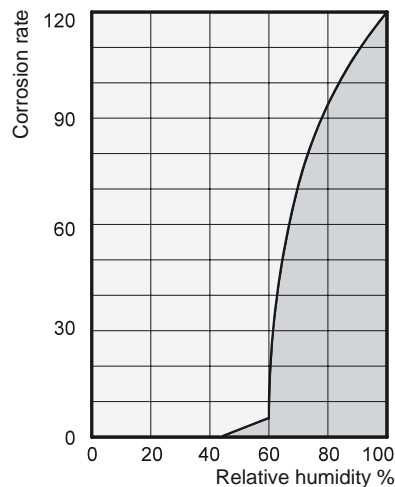

It is evident that the corrosion rate below 50 % relative humidity (RH) is low, and below 40 % is negligible.

The corrosion rate increases significantly above 60% RH. This threshold for damage as the result of humidity also applies to other materials, such as powdery substances, packaging, wood and electronic units.

Buildings may be dried in a variety of ways:

#### 1. By heating and air exchange:

The air in the room is heated in order for moisture to be removed and then this air is fed outside. All of the energy that is involved is lost together with the moist air that is released.

#### 2. By air dehumidification:

The moist air that is present within an enclosed space is continuously dehumidified according to the condensation principle.

With regard to energy consumption, air dehumidification has one distinct advantage:

Energy expenditure is limited exclusively to the air volumes present. The mechanical heat that is released by the dehumidification process is fed back into the room.

**Under normal use, the air dehumidifier uses approximately 25 % of the energy that is required for the "heating and ventilating" principle.**

### Relative air humidity

Our ambient air is a gaseous mixture which always contains a certain volume of water in the form of water vapour. This volume of water is specified in g per kg of dry air (absolute moisture content).

**1 m<sup>3</sup> of air weighs approx. 1.2 kg at 20 °C**

Depending on the temperature, each kg of air is only capable of absorbing a certain volume of water vapour. Once this capacity has been reached, the air is referred to as "saturated" and has a relative humidity (RH) of 100 %.

Relative humidity is understood to mean the ratio between the current quantity of water vapour in the air and the maximum possible quantity of water vapour at the same temperature.

The ability of the air to absorb water vapour increases as the temperature rises. I.e. the maximum possible (absolute) water content becomes greater as the temperature rises.

# REMKO SLE series

Temp.	Water vapour content in g/m <sup>3</sup> at humidity of			
	40%	60%	80%	100%
°C				
-5	1.3	1.9	2.6	3.3
+10	3.8	5.6	7.5	9.4
+15	5.1	7.7	10.2	12.8
+20	6.9	10.4	13.8	17.3
+25	9.2	13.8	18.4	23.0
+30	12.9	18.2	24.3	30.3

## Water vapour condensation

Because the capacity for the maximum possible volume of water vapour increases as the air is heated, the volume of water vapour contained remains constant and so relative humidity falls.

In contrast, because the capacity for the maximum possible volume of water vapour decreases as the air is cooled, the volume of water vapour contained remains constant and so relative humidity increases. If the temperature continues to fall, the capacity for the maximum possible volume of water vapour is reduced so much so that it is ultimately equal to the volume of water vapour contained in the air. This temperature is referred to as the dew point. If the air is cooled to below the dew point, the volume of water vapour in the air will become greater than the maximum possible volume of water vapour.

At this point, the water vapour begins to precipitate. It then condenses to water. Humidity is then removed from the air.

## Drying materials

Building materials and structures are capable of absorbing considerable volumes of water, such as brick 90-190 l/m<sup>3</sup>, heavy concrete 140-190 l/m<sup>3</sup> and limestone 180-270 l/m<sup>3</sup>. The drying of moist materials such as masonry is effected as follows:

- The moisture moves from the inside of the material to its surface

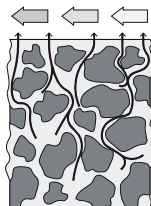

- Evaporation occurs on the surface = transfer of water vapour to the ambient air

- The air containing water vapour is constantly circulated through the REMKO air dehumidifier. The air is dehumidified and, slightly heated, leaves the unit in order to re-absorb water vapour

- In this way, the moisture contained in the material is reduced gradually  
**The material is dried!**

The accumulated condensate is collected in the unit and drained off from there.

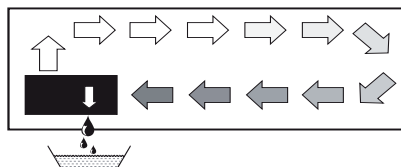

As it flows through or over the evaporator, the air stream is cooled to dew point. The water vapour condenses, and is collected in a condensate trap from where it is drained off.

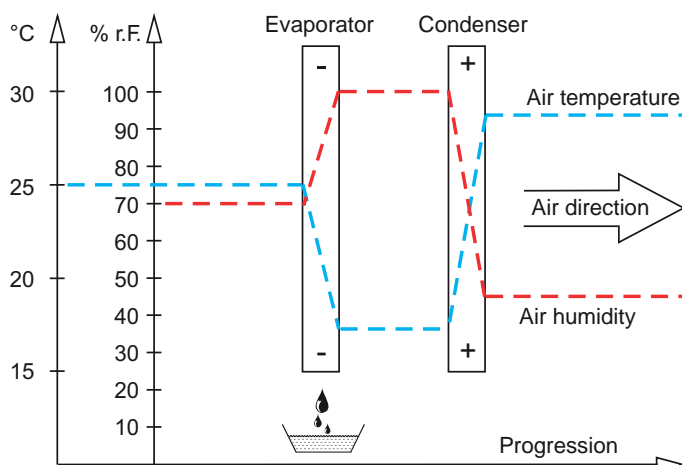

Examples of condensation include steamed-up window panes in winter, or the moisture on the outside of a cold drinks bottle.



As the relative humidity of the air increases, so too does the dew point, making it easier for the temperature to fall below it.

## Condensation heat

The Energy transferred to the air from the condenser consists of:

1. The amount of heat derived beforehand in the evaporator.
2. The electrical drive energy.
3. The condensation heat released by liquefying the water vapour.

Energy must be supplied when liquid is converted into a gas. This energy is designated as evaporation heat.

It does not cause any increase in temperature, but is required to convert a liquid into a gas.

Conversely, energy is released when gas is liquefied, this is designated as condensation heat.

The amount of energy from evaporation heat and condensation heat is the same.

**For water, this is:  
2250 kJ/kg (4.18 kJ = 1kcal)**

From this it is evident that the condensation of water vapour causes a large quantity of energy to be released.

If the moisture that it is to be condensed is not introduced by evaporation in the room itself, but from outside, e.g. through ventilation, the condensation heat released contributes to the heating of the room.

When dehumidifying, a heat cycle is created, whereby heat is consumed for evaporation and released for condensation.

When dehumidifying fed air, a larger contribution of heat is created, which manifests itself as a temperature increase.

**Generally speaking, the time required for the drying process is not only dependent on the output of the unit, but is determined to a greater extent by the speed at which the material or building section loses its moisture.**

# REMKO SLE series

## Testing the water quality

### Water quality

The correct combination of chemicals in swimming pools in indoor areas is of major importance to the health of the users and for systems in the vicinity of the swimming pool and its plant room.

Inadequately treated water leads to poor hygiene, whilst water that has been excessively treated gives off chlorine into the air, which can irritate the eyes and lead to respiratory problems. At the same time, an incorrect combination of chemicals in the water can lead within a very short time to the destruction of all systems - including the dehumidifier and other systems that have been installed for air treatment.

The following tables contain the limit values for swimming pools in indoor areas in accordance with EN/ISO 12944-2, corrosivity category C4.

These limit values must be observed, otherwise the guarantee is voided

### When adding chemicals

The following guideline values apply to swimming pools when adding chemicals:

Chemical values	ppm
Free chlorine content	1,0 - 2,0
Combined chlorine content	max. 1/3 of the free chlorine content
pH value	7,2 - 7,6
Total alkalinity	80 - 150
Calcium hardness	250 - 450
Total dissolved solids	< 2000
Sulphates	< 360

### With own production of chlorine

The following guideline values apply to swimming pools with own production of chlorine:

Chemical values	ppm
Salt (NaCl)	< 30000
Total dissolved solids	< 5 500
pH value	7,2 - 7,6
Total alkalinity	80 - 150
Calcium hardness	250 - 450
Sulphates	< 360

### Langelier saturation index

To make sure the various water quality parameters remain within an acceptable range, the Langelier saturation index should be applied.



## Unit description

The units have been designed for universal and straightforward air dehumidification.

Their compact dimensions allow the units to be transported and installed with ease in the adjacent room.

The units operate in accordance with the condensation principle and are equipped with a hermetically sealed refrigerant system and low-noise and low-maintenance fan(s).

The fully-automated electronic controller, an integrated hygostat and connection ports for condensate drainage provided by the customer ensure continuous fault-free operation.

The units are reliable, easy to use and conform to the fundamental health and safety requirements of the appropriate EU stipulations.

The units are used in all locations where dry air is a must and where economic consequential damage (such as that caused by mould) must be prevented.

### The units may be used to dehumidify areas such as:

- Private swimming pools
- Spa areas
- Fitness centres
- Storage rooms
- Archives
- Museums

### Operating sequence

The unit is switched on and off using the integrated hygostat.

*The hygostat is set to 60 % RH in the factory.*

The respective unit function is indicated by a multi-colour LED display on the front of the unit.

The fan extracts the moist room air via the lower part of the front panel.

Heat is removed from the room air on the cold *evaporator*. The air is then cooled to below dew point.

The water vapour contained in the room air is then deposited as condensate or rime on the evaporator fins.

On the *condenser*, the cold and dehumidified air is warmed up again and discharged back into the room via the top part of the front panel with a temperature increase of around 5 K above the room temperature.

The processed, dry air therefore continuously mixes with the room air.

Continuous circulation of the room air through the unit gradually reduces the relative humidity (% RH) in the room to the desired humidity level.

### LED light function

If the unit was delivered with the LED light function, the light can be switched on and off using an operating switch at the top right corner of the panel. If designed as an RGB-LED, a remote control is also supplied.

Schematic depiction of the workings of the SLE 45-85 air dehumidifier

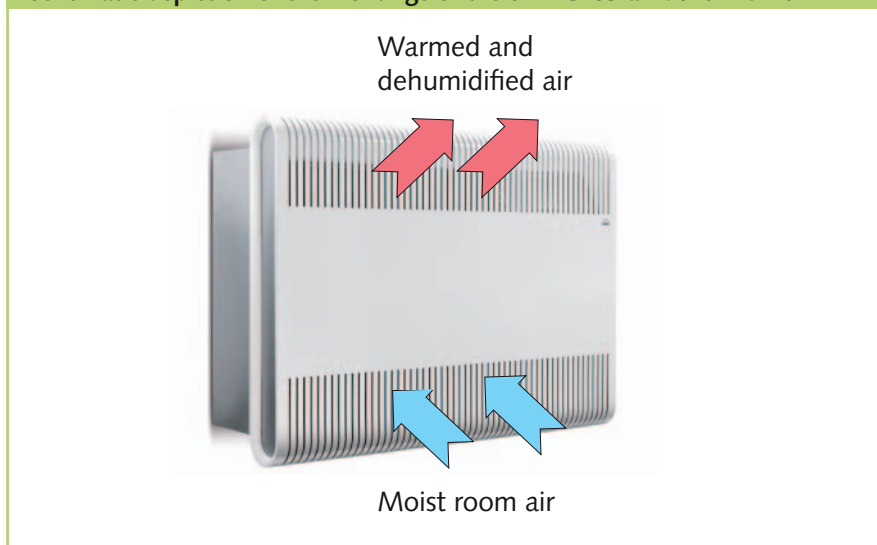

LED light function



# REMKO SLE series

## Set-up

For optimum and safe use of the units, the following notes must be followed in full:

### ⚠ CAUTION

*The units are set up in areas with a high potential for hazards. In addition to the local regulations, the VDE regulations relating to safety zones, local potential equalisation, equipment, safety measures and protection classes must be adhered to.*

- Comply with all regulations governing structural, electrical and other building requirements and conditions with regard to the installation site
- Mount the wall console provided securely to the wall using suitable fastening fixtures (not included)
- The unit must be mounted or set up upright to ensure that the condensate can drain freely
- The unit's alignment must be adhered to exactly in order to prevent warpage on the housing and to ensure that the unit panel can be put on without hindrances
- The unit must be mounted or set up upright to ensure that air can be taken in and blown out freely
- Observe the illustrated minimum gaps between the unit and the ceiling and floor in the installation room to ensure safe operation
- The unit must never be mounted in the immediate vicinity of heaters or other sources of heat
- The room being dehumidified must be closed to the neighbouring atmosphere
- Avoid having opened windows and doors etc., and avoid frequent entry to or exit from the room as much as possible
- In order to achieve optimum room air circulation using the dehumidifier, the supply and exhaust air openings must remain clear
- Secure the wall spacers provided with the unit to the bottom corners of the unit using adhesive

### Mounting the units on the wall

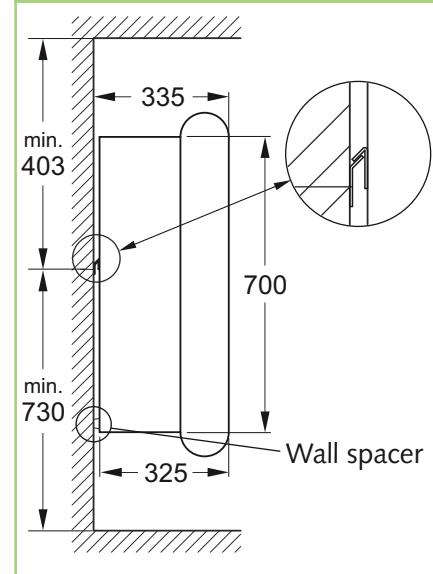

### Access to the controller

The unit panel must first be removed from the unit in order to access the controller. To do this, remove the bottom lock. Angle the front panel downwards and then lift up and off vertically.

The controller is located behind the top cover of the internal housing parts above the compressor.

Once the top two screws on the inner housing parts are removed, the top panel can be removed and access is free.

Once work is completed, re-install or lock the housing parts accordingly.

### Wall-mounted bracket for the units

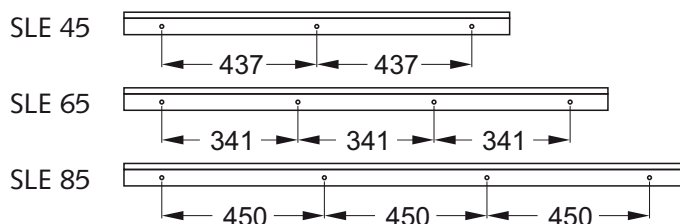

## Condensate water drain

The condensate water drain is located on the unit's base. The condensate drain is connected to the discharge nozzle supplied. A solid or flexible 3/4" discharge connector can be installed on this.

- The discharge hose must always be laid at an incline of at least 2 % so that the water can flow unhindered from the drip tray.
- Alternatively, a condensate pump can be fitted to the unit in order to pump the condensate water to a drainage point located at a higher level.
- If drainage is to be carried out through the wall, the relevant measures such as holes for correct condensate drainage must be taken before installing the unit.
- See the diagram at the side for information on the location of the drainage connection.

### Location of the condensate drain

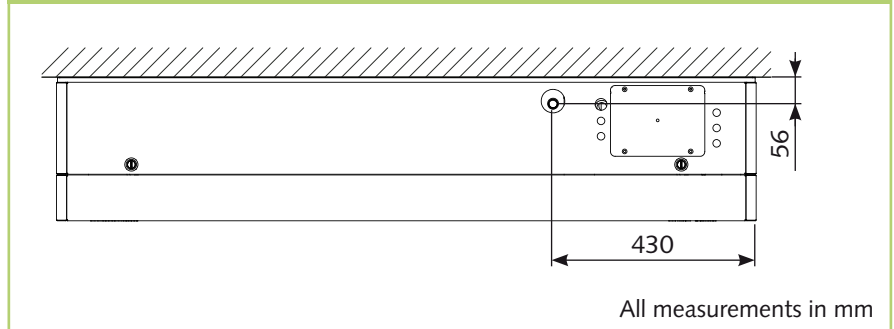

## Putting the panel on

The unit is supplied from the factory with a separate panel. This must therefore be put on properly before starting the unit. Follow one of the following two instructions depending on the unit equipment.

### Installing the SLE panel without LED light function

To equip the unit with the panel, follow these instructions.

1. Open the connection flap on the bottom.
2. Guide the power cable through the cable gland and then onwards to the terminal block.
3. Then attach the cable for the power supply. Connect the L1 phase accordingly to the first grey terminal (L1) from the left. Connect the zero phase N to the first blue terminal (N) from the left and connect the earth conductor PE to the earth conductor terminal (PE) (also see the electrical wiring diagram).

4. Re-close and fasten the connection flap.
5. Connect the unit to the power supply.
6. Remove the control board cover.
7. Set the room humidity on the control board (see commissioning).
8. Re-attach the control board cover using the two screws.
9. Hang the SLE panel into the top edge, use the top guide pins to centre it and then let it rest gently.
10. Push the panel using the bottom guide pins.
11. Tighten the two locks clockwise so that the bottom of the panel can no longer be lifted.

# REMKO SLE series

## Installing the SLE panel with LED light function

To equip the unit with a panel for the LED light function, follow these instructions.

1. Open the connection flap on the bottom.
2. Connect the supplied cable section (0.5 m) with plug contact. Connect the brown cable to the second grey terminal (L1) from the left. Connect the blue cable to the second blue terminal (N) from the left.
3. Push the strain relief onto the rail and push the two cable ties through the eyes.
4. Guide the cable end with the plug contact through the bottom gap. Attach the cable with the cable ties to the strain relief and shorten the ends of the cable ties accordingly.
5. Guide the power cable through the cable gland and then onwards to the terminal block.
6. Then attach the cable for the power supply. Connect the L1 phase accordingly to the first grey terminal (L1) from the left. Connect the zero phase N to the first blue terminal (N) from the left and connect the earth conductor PE to the earth conductor terminal (PE) (also see the electrical wiring diagram).

### 1. Opening the connection flap

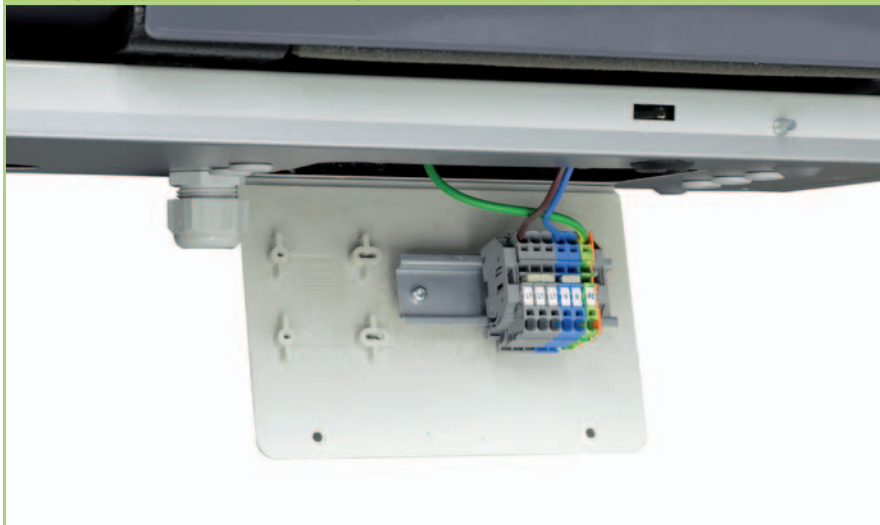

### 2. Connecting the cable section

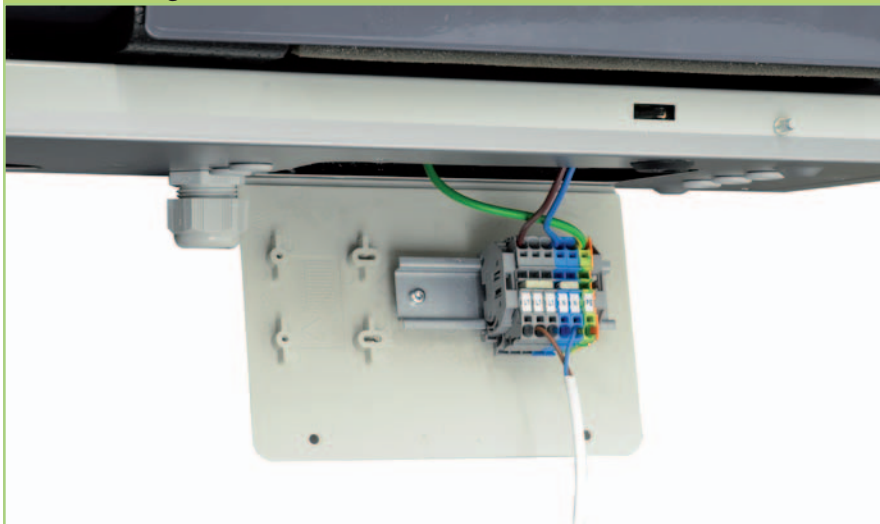

### 3.-6. Strain relief and power supply

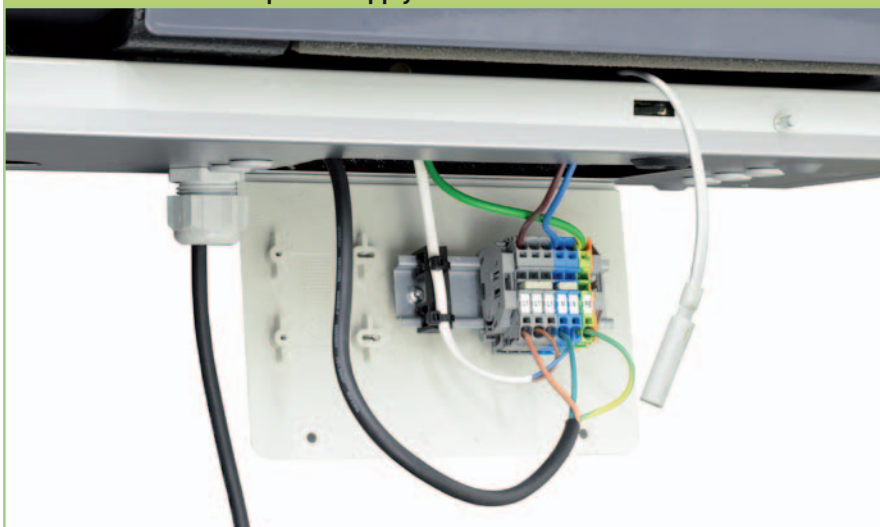

7. Re-close and fasten the connection flap.
8. Connect the unit to the power supply.
9. Remove the control board cover.
10. Set the room humidity on the control board (see commissioning).
11. Re-attach the control board cover using the two screws.
12. Disconnect the unit from the power supply.
13. Hang the SLE panel with LED function into the top edge, use the top guide pins to centre it and then let it rest gently.
14. Angle the panel slightly downwards and connect the plug contact on the terminal block to the plug contact on the panel.
15. Stow the cable in the connection box.
16. Push the panel using the bottom guide pins.
17. Tighten the two locks clockwise so that the bottom of the panel can no longer be lifted.

#### 7. Closing the connection flap



#### 8.-12. Control board



#### 13.-17. Putting the unit panel on



# REMKO SLE series

## Commissioning

Before commissioning the unit or if local requirements dictate, the air-inlet grill and air-outlet grill must be checked for contamination.

The units are operated using an integrated hygrostat that is set to 60 % RH (default value for spas and indoor swimming pools). If the room humidity is below 60 % RH, the unit does not start. If the relative humidity is above 60 %, the unit starts the dehumidification process automatically.

If you would like to make changes to the hygrostat settings, remove the front panel and the control board cover located in the upper section in order to access the control board.



### NOTE

Interrupting the operation of the unit before the compressor has run for 6 minutes will activate a restart lock lasting approx. 4 minutes.



### NOTE

If the air humidity is lower than the set value, the unit will not start up, even if the mains voltage is connected.



### NOTE

When the unit is switched on or off using the main switch, a signal is issued upon startup and the operation LED display illuminates blue as soon as the unit is ready for operation. Once all conditions have been met, the dehumidifying process begins.

## Control board

The units are equipped with an electronic controller. This features various interfaces and a display. The following section describes these features in detail.

## USB interface

The information on the USB interface can be found further on in this manual.

## RS-485 interface

The information on the RS-485 interface can be found further on in this manual.

### Control board, front

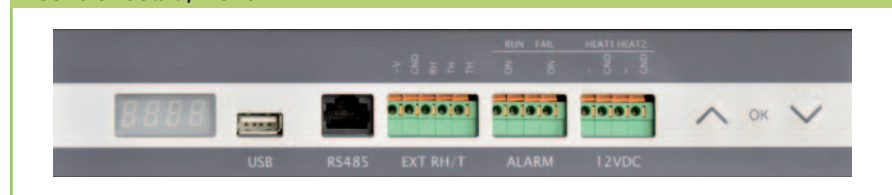

## Display and operator panel

The display is a four-digit seven segment display. The first two digits are used to display the respective "code", e.g. rHXX, for setting the room humidity and the last two digits correspond to the value set.

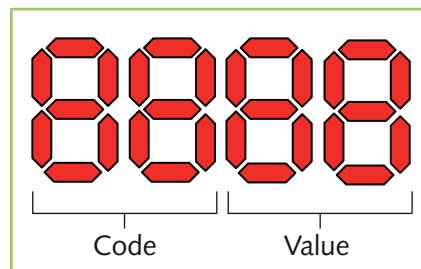

In the standard view, no code is shown on the display. It is only the value of the humidity currently measured that is displayed.

The operator panel with the buttons "Up", "Down" and "OK" can be found on the right-hand side of the front of the control board. These can be used to navigate around the menu structure of the control board and to couple the control board with a wireless remote control.

## EXT RH/T

These terminals allow you to connect up an external electronic humidity and temperature probe. The temperature probe must be an NTC probe with 10 kΩ at 25 °C and a B25/85 of 3969 K. The humidity probe must be designed for a voltage supply of 12 V DC and feature an analogue voltage output of 0-10 V with max. 10 mA.

## ALARM

The alarm contacts are two potential-free contacts that are open in an unswitched state. The RUN contact is closed when the compressor is in operation. The FAIL contact is closed when there is a malfunction in the unit.

## 12VDC

Relays can be controlled via the HEAT contacts in order to switch the external heating on and off. They are active when the °C option in the menu is set to a value.

## Menu structure

To define the setpoints using the integrated operator panel, hold down the "OK" key for 5 seconds so that the display switches from the humidity currently measured to the menu item rHXX.

If you would like to exit the menu, do not press any keys on the operator panel for 10 seconds.

## Menu items

Code: RH

The code "RH" stands for the relative air humidity that the unit should reach. The value can be set between 40 and 99 % RH. The default value is 60.

Code: °C

The code "°C" stands for external heating control with the aim of reaching a defined setpoint. The value can be set to between 05 and 34. This value is set to "OF" by default.

Code: EF

The code "EF" stands for external heating control with the aim of reaching the specified air humidity more quickly. The set value may differ from the setpoint humidity so that the external heating can either operate permanently or merely provide a support function. The value can be set between 40 and 99 % RH. The default value is set to "OF".

Code: SI

The code "SI" stands for the maintenance interval that the operator or fitter requires. This value is indicated in weeks and can be set from 01 to 99. The default value is "OF."

Code: tE

The code "tE" stands for testing and the value "St" for self-test. To start the self-test, press "OK" and to cancel it, hold the down key down for 5 seconds.

### NOTE

*The corresponding terminals for these options are located on the control board of the unit.*

## Menu structure of the SLE air dehumidifier

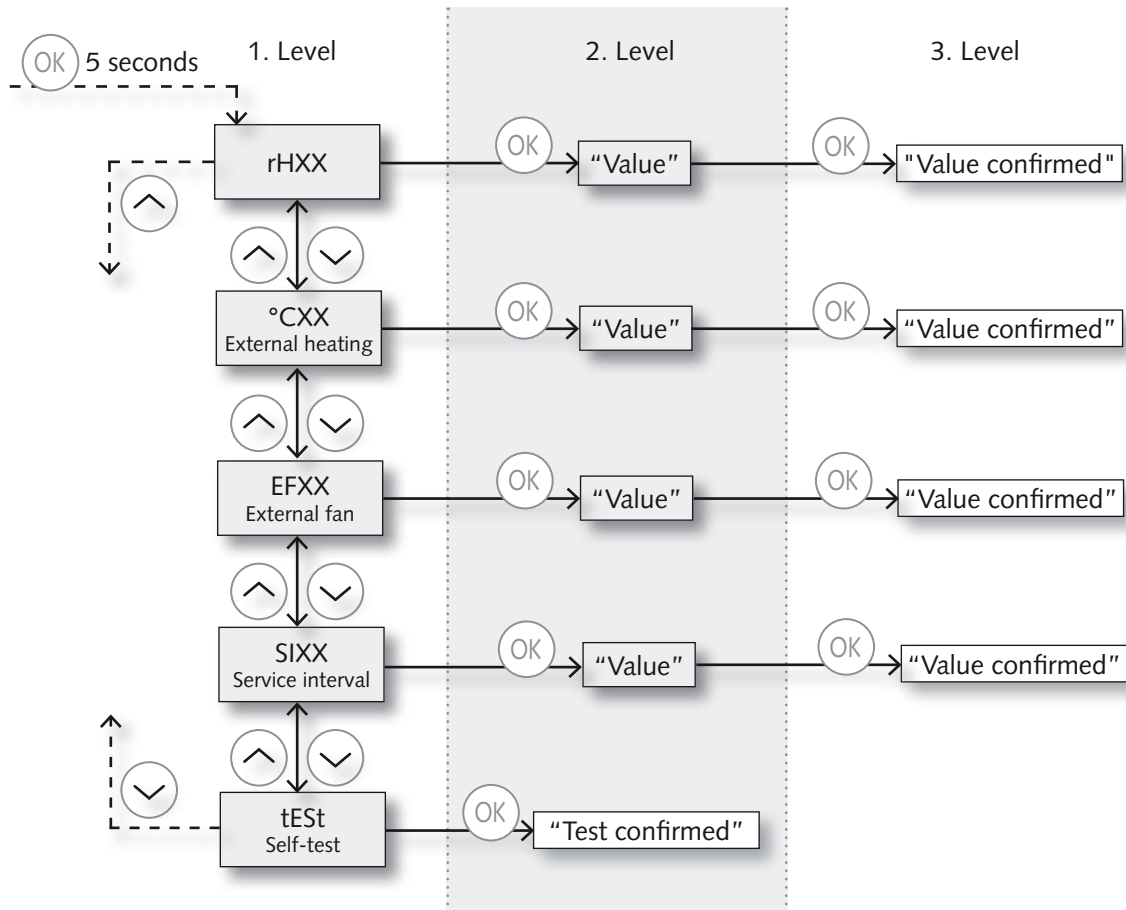

# REMKO SLE series

## Unit function

### Fan control

When the control board puts the dehumidifier into operation, the fan(s) switch on together with the compressor.

### Defrosting

The units feature an intelligent and active defrosting function. If the room temperature is below 20 °C, the evaporator will start to ice up after a short time.

If the evaporator probe registers a temperature of less than 5 °C on the evaporator surface, the unit only continues to run in dehumidification mode for a further 30 minutes.

Once this time has expired, the fans stop and the solenoid valve for hot-gas defrosting opens. When the evaporator probe registers a temperature higher than 5 °C again, the solenoid valve closes and the unit resumes dehumidification.

### Safety circuit

If the temperature exceeds 55 °C on the condenser (e.g. due to a fan failure or an overly high room temperature (higher than 36 °C)), the compressor stops automatically to prevent an overload.

As soon as the temperature on the condenser permits dehumidification again, the unit starts up automatically.

### Compressor control

The compressor has a 6 minute restart delay. The delay period must elapse before it is possible to restart the compressor. This safety function protects the compressor against an overload caused by overly high pressure in the cooling cycle.

In order to prevent damage to the condenser, the units are equipped with a mechanism that prevents the compressor being immediately switched back on after it is switched off via the mains power supply.

**The compressor does not switch back on until after a waiting time of approx. 30 seconds!**

### Operating LED

The multi-colour LED display is in the background of the top grille on the front panel. It indicates the current operating state of the unit.

### Legend of the operation LED colours

The LED illuminates “blue” and stays that way when the unit is connected to the mains power supply (standby).

The LED illuminates “green” and stays that way when the compressor is in operation and the unit is in dehumidifying or defrosting mode.

The LED lights up “yellow” and stays that way when the unit is operating in wireless remote control mode.

The LED lights up “red” when a fault has occurred. Please refer to the Troubleshooting chapter to rectify the fault.

### LED light function

If the unit was delivered with the LED light function, the light can be switched on and off using an operating switch at the top right corner of the panel. If designed as an RGB-LED, a remote control is also supplied.

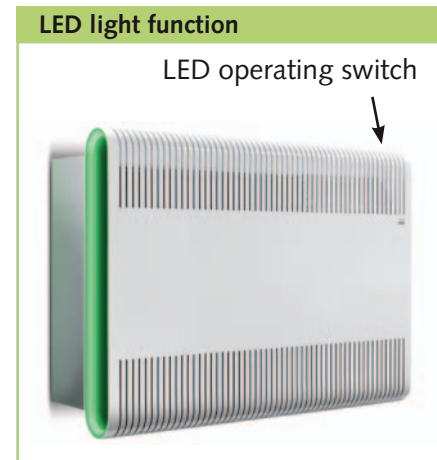



## Wireless remote control

The wireless remote control allows an SLE unit to be operated and adjusted in a simple and convenient manner. The current humidity and temperature can be viewed on the wireless remote control and the setpoint humidity can be adjusted.

The wireless remote control is intended for use with the SLE 45-65-85 dehumidifier models.

The wireless remote control has a coverage distance of up to 50 metres from the installation location of the unit.

### Design of the wireless remote control

The wireless remote control is equipped with a large, clear display and has operating buttons for the different options Up, Down, Left, Right and Enter.

The display values and the air humidity scale have a value range of 0 to 99 % RH.

The display values and the air temperature scale have a value range of 0 °C to 40 °C.

### Information display

The information display shows the setpoint values for the unit. Fault messages together with the fault symbols are also displayed here.

### Power supply

The wireless remote control can be powered using 2 AAA batteries with 1.5 V each or can be powered externally using the USB cable provided.

### Wireless remote control



### Overview of the display

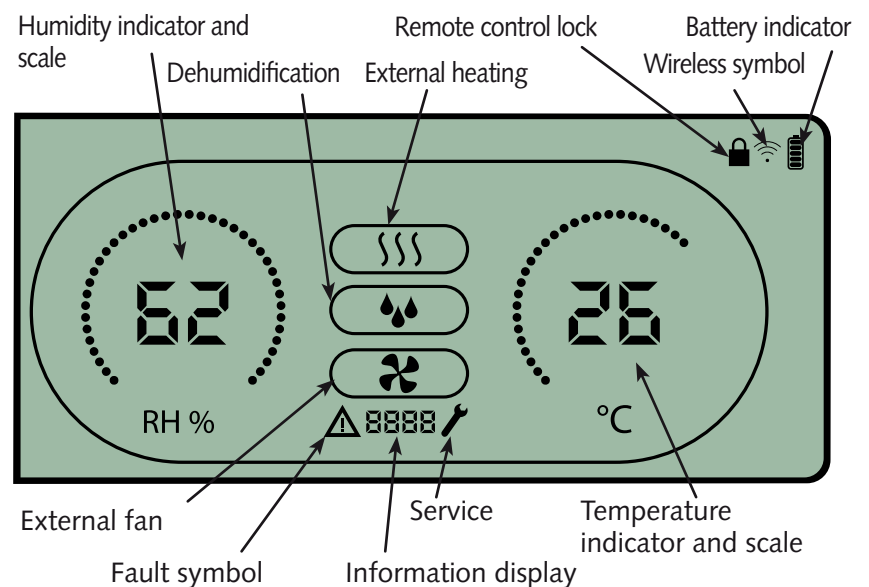

### Operating button control options

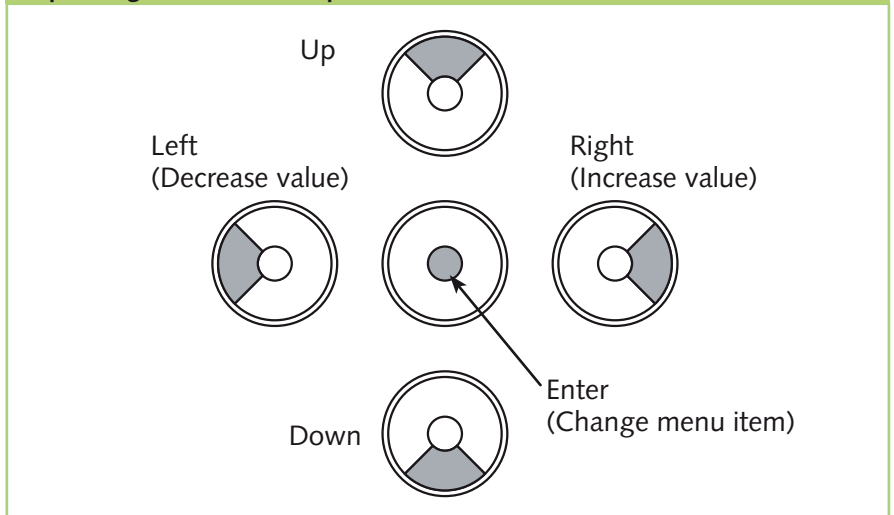

# REMKO SLE series

## Coupling

### Connecting the antenna

The antenna is located on the control board inside the unit or can be fitted there. This will be pre-installed if the unit is delivered together with the remote control. Before fitting the antenna, disconnect the unit from the power supply. Then loosen the two locks on the bottom of the unit by turning them anticlockwise, tilt the front cover of the unit and lift it up. In the upper right area, remove the two screws on the board cover and remove the cover. Pull the control board forwards, screw the antenna into place and bend it forwards. Once the antenna is screwed in place and the board has been returned to the previous position, the unit can now be provided with power in order to couple it with the wireless remote control. Then screw the housing parts back into place.

### Switching on and coupling the remote control

The wireless remote control must be coupled with the unit before it can be used. To do so, carry out the following steps.

1. Insert the batteries provided into the battery compartment on the rear of the wireless remote control.
- 2a. The remote control will search for the unit for two minutes. During this time, the remote control display flashes every 2 seconds.
- 2b. During the search phase, hold down the Up and Down keys on the operator panel of the control board at the same time for 5 seconds.

### Location of the control board



### Connecting the antenna



3. If coupling was successful, the unit sends a serial number to the wireless remote control and the wireless symbol is displayed.
4. The swimming pool dehumidifier confirms the connection by displaying the code "Conn" for a period of 3 seconds.

This procedure can also be carried out using several remote controls so that an air dehumidifier can be controller by several remote controls.

### Coupling failure

If the wireless remote control fails to couple with the unit, the fault symbol becomes visible, "Conn" is shown permanently on the display and the wireless symbol flashes.

The wireless remote control needs to be reset before a new coupling attempt can be made. To do so, hold the Left key on the wireless remote control down for 10 seconds.

## General

The wireless remote control displays the values for humidity and temperature at all times. The values only disappear when a malfunction arises. Depending on which function is currently active, one or more of the symbols appear in the centre of the display.

## User setup menu

Hold down the Enter key for 3 seconds to open the user setup menu.

In this menu it is possible to switch between the wireless remote control symbols using the Up and Down keys provided the corresponding option of "OF" has been set to a value on the control board itself. Please read pages 12 and 13 to set these values.

### User setup menu symbols

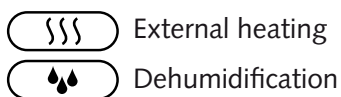

The Left and Right keys can be used to set these parameter values. The parameter is confirmed as a new setpoint using the Enter key. When this is confirmed, the remote control switches back to the symbol and exits the menu. If you would like to exit the user setup menu, do not press any keys on the remote control for 10 seconds.

## Fitter setup menu

Hold down the Right key for 5 seconds to open the fitter setup menu. At this point it is possible to access all four menu items. It is also necessary to set the respective "OF" option on the control board to a specific value to enable access.

### Fitter setup menu symbols

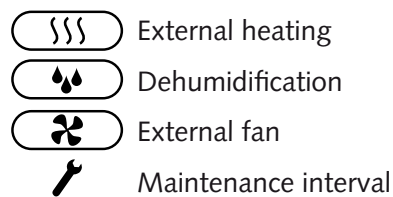

## Fault messages

The fault messages correspond to the alarm messages which can also be shown on the unit's control board display. To make the alarm message recognizable, the fault symbol is also displayed on the wireless remote control.

### Examples of fault messages

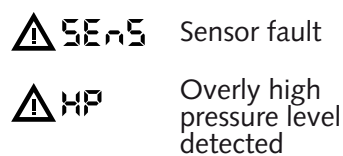

Generally speaking, the fault messages can only be reset on the display panel of the control board. The unit must be thoroughly inspected and the fault reset following rectification each and every time.

No changes can be made to the setpoints in the setup menus while there is an active fault.

## Fault priority

In the event that several faults occur at the same time, only the fault with the highest priority is displayed.

### Fault priority



### NOTE

*Do not simply reset the fault messages without establishing the cause first.*

## Maintenance message

Unlike the other fault messages, the maintenance message can be acknowledged or reset via the wireless remote control. This is due to the fact that it is a purely informative message.

### Maintenance message



Proceed as follows to set up the new maintenance interval.

1. Hold down the Right key for 5 seconds to open the fitter menu.
2. Use the Up and Down keys to navigate to the maintenance symbol.
3. Use the Right and Left keys to change the 0 value to the required maintenance interval.
4. Confirm the new maintenance interval by pressing the Enter key.

# REMKO SLE series

## LED wireless remote control

The LED wireless remote control is used to set the colour modes.

The LED wireless remote control is intended for use with SLE 45-65-85 dehumidifier models that are equipped with the RGB LED light function.

The LED wireless remote control has a coverage distance of up to 50 metres from the installation location of the unit.

### Sleep mode

If the LED wireless remote control is not used for more than 30 seconds, it switches to sleep mode in order to save battery power. Pressing any key deactivates sleep mode and the LED wireless remote control can be used for setting again.

### Using the LED remote control to change modes

You can use the "Change mode" key to select from 11 different programs.

1. Solid colour, red
2. Solid colour, green
3. Solid colour, blue
4. Solid colour, yellow
5. Solid colour, violet
6. Solid colour, turquoise
7. Solid colour, white
8. RGB alternating (jumping)
9. Seven alternating colours (jumping)
10. RGB alternating (cross-fading)
11. All colour alternating (cross-fading)

### LED wireless remote control (RGB)

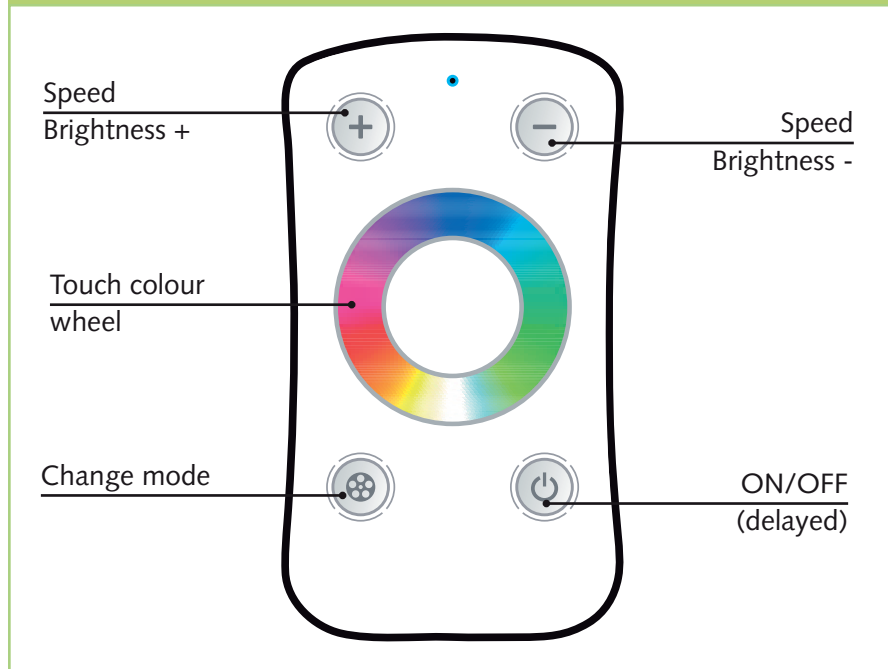

### Changing the battery

The battery compartment is located on the bottom of the remote control. 1x CR2032 is inserted here. The battery compartment must be closed completely.

### NOTE

*Pay attention to the polarity when inserting the battery.*

### CAUTION

*The fast light changes and light intensity changes can affect cognition, cause complaints and trigger epileptic fits in people prone to them.*

### CAUTION

*If damage results in the LEDs being directly visible, avoid looking into the LEDs. The high light intensity can cause damage to the retina.*

## Care and maintenance

### NOTE

*Regular care and maintenance is fundamental to a long service life and fault-free operation of the unit.*

All moving parts have a low-maintenance permanent coat of lubricant. The refrigerant system is designed as a hermetically sealed system and may only be repaired by a specialist.

- Observe the regular care and maintenance intervals
- In accordance with the operating conditions, the units must be checked as and when required, but at least once per year, by a specialist to ensure that they are in a condition that is safe to use
- Keep the units free of dust and other debris
- If the unit is contaminated, it can be cleaned using a vacuum cleaner. The condenser in particular must be vacuumed thoroughly
- If the evaporator's fins are heavily soiled, they can be cleaned carefully with soapy water
- Never subject to direct jets of water **e.g. pressure washers etc.**
- Never use abrasive or solvent-based cleaners
- Use only suitable cleaners, even for heavy contamination

### Cleaning the suction filter

Check the suction filter at regular intervals and clean if necessary. The filter is secured in the intake grille on the front panel.

### CAUTION

*Check the intake and outlet openings, as well as filters, regularly for contamination.*

- Light filter contamination can be remedied with careful blowing or suction
- Heavier contamination may be remedied by rinsing the filter in a lukewarm (max. 40 °C) soap solution. Finally, always rinse the filter carefully with clear water and allow to dry
- Before refitting the filter, ensure that it's fully dry and that no damage has been sustained
- The units may only be operated with the filter in place

### NOTE

*Heavily contaminated filters must be replaced with new parts. Only original REMKO spare parts may be used.*

### Cleaning the condensate water collection tray

To ensure that the condensate water that accumulates can always drain freely, the collection tray for the condensate and the drain must be cleaned regularly.

# REMKO SLE series

## Troubleshooting

Malfunction	Possible cause	Remedial measures
<ul style="list-style-type: none"> <li>The unit does not start.</li> <li>The display does not light up.</li> <li>The LED does not illuminate.</li> </ul>	No mains voltage.	<ul style="list-style-type: none"> <li>Check the power supply or fuses or switches on site.</li> </ul>
<ul style="list-style-type: none"> <li>The unit does not start.</li> </ul>	<p>Air humidity in room too low.</p> <p>Probe defective.</p> <p>High/low pressure malfunction.</p> <p>The unit is not within its usable limits of 10 - 36 °C.</p>	<ul style="list-style-type: none"> <li>Check the integrated hygostat and set it to a low relative humidity, e.g. 40 % RH.</li> <li>Ensure that the room humidity is not below 40 % RH.</li> <li>Contact a qualified technician.</li> <li>Check the room conditions and alter as required.</li> </ul>
<ul style="list-style-type: none"> <li>The compressor does not start.</li> </ul>	<p>The compressor switched off automatically due to an overly high condenser temperature.</p> <p>Lack of air ventilation.</p> <p>Overly high ambient temperature.</p> <p>Contaminated filter/intake device.</p>	<p>Check the following points if the unit does not start after 45 minutes:</p> <ul style="list-style-type: none"> <li>Check if the fan(s) is/are working.</li> <li>Check if the intake filter is contaminated.</li> <li>Check that the intake and outlet openings are free of contamination.</li> <li>Check whether the heat exchanger fins are contaminated.</li> <li>Check whether the room temperature is above 36 °C. If the room temperature is above 36°C, the unit must be switched off.</li> </ul>

### NOTE

*If it is not possible to determine the cause of the fault, switch off the unit immediately and disconnect it from the mains power supply to prevent further damage.*

### CAUTION

*Work on the refrigerant system and on the electrical equipment must only be conducted by a specially-authorized specialist!*

### CAUTION

*Prior to maintenance or repair work, the unit must be disconnected from the mains power supply.*

### NOTE

*If all of the functional checks have been carried out without any findings, please contact an authorized service station.*

## Fault messages

Code and value	Cause	Remedial measures
LOSS	The connection to the remote control has been lost	When the connection is restored, acknowledge by clicking "OK".
Abt	Ambient temperature is not within the permissible range	Acknowledgement not possible. Automatic reset as soon as the temperature has returned to the permissible range.
AbrH	Air humidity is not within the permissible range	Acknowledgement not possible. Automatic reset as soon as the air humidity has returned to the permissible range.
SEnS	Sensor fault, causes the unit to stop	<p>Press the Up or Down key to see which probe is affected. Exchange the probe if necessary.</p> <p>COnd - condenser probe EUAP - evaporator probe RH<sup>t</sup> - humidity and temperature probe</p> <p>Acknowledgement possible only by way of unlocking sequence. Initiate the sequence by pressing the "OK" key.</p>
LP	Low pressure level detected	Malfunction must be established and rectified by specialist personnel. Acknowledgement possible only by way of unlocking sequence. Initiate the sequence by pressing the "OK" key.
HP	High pressure level detected	Malfunction must be established and rectified by specialist personnel. Acknowledgement possible only by way of unlocking sequence. Initiate the sequence by pressing the "OK" key.

### Unlocking sequence

If the SEnS, LP or LH fault is present, pressing "OK" initiates the unlocking sequence. Once the unlocking sequence has been initiated, the unit displays the information "Loc". If the Down key is pressed at this point, the information display switches to "UnLo" which displays the unlocking option. If "UnLo" is confirmed with the "OK" key, the unit is enabled again.

## Information messages

Code and value	Occurrence	Comment
Log	After inserting a USB memory stick into the USB interface	Once the USB stick has been inserted, the process of copying the log data from the internal memory to the USB memory stick is initiated and declared as finished by the information "Log".

# REMKO SLE series

## Cooling cycle

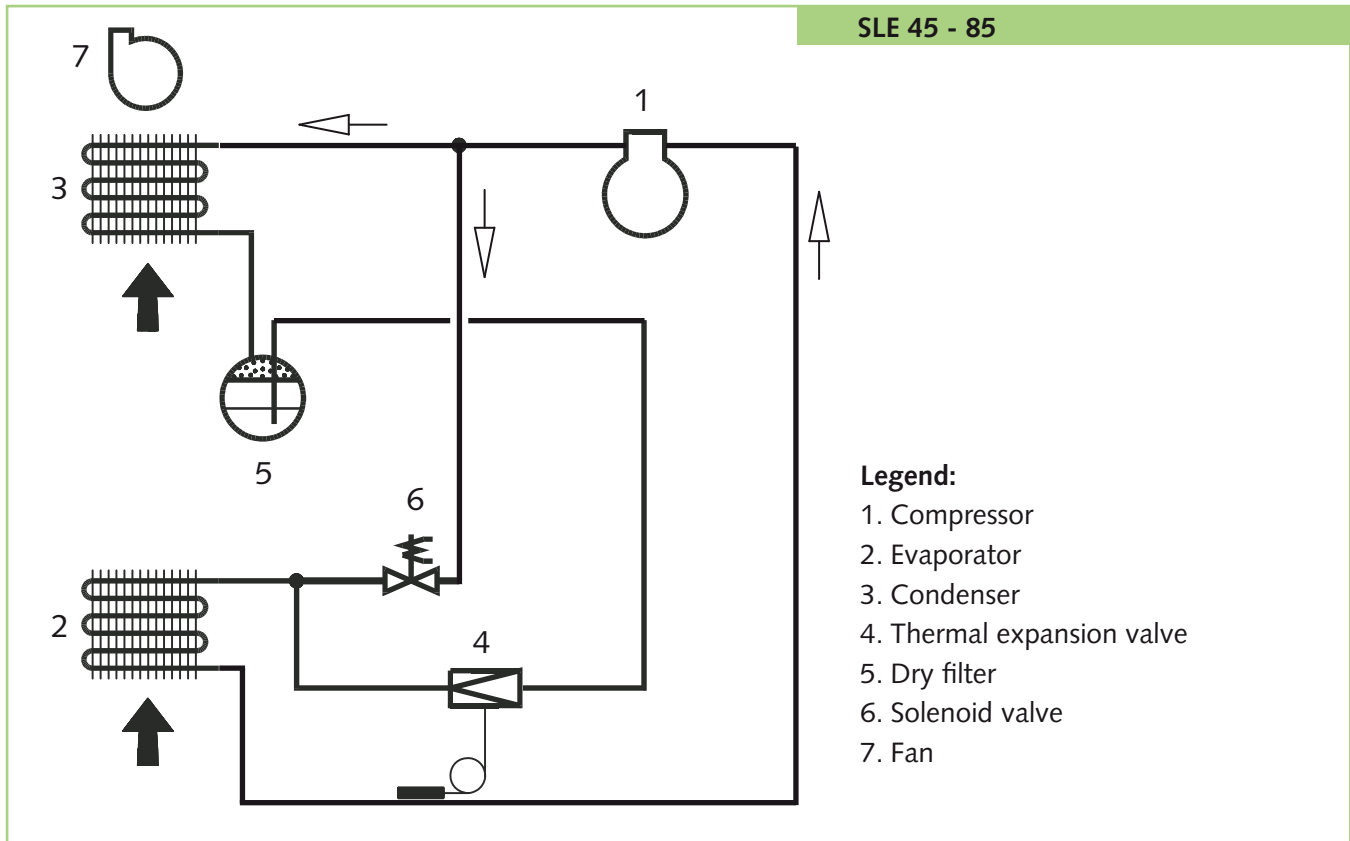

We reserve the right to modify the dimensions and design as part of the ongoing technical development process.



## Electrical wiring diagram

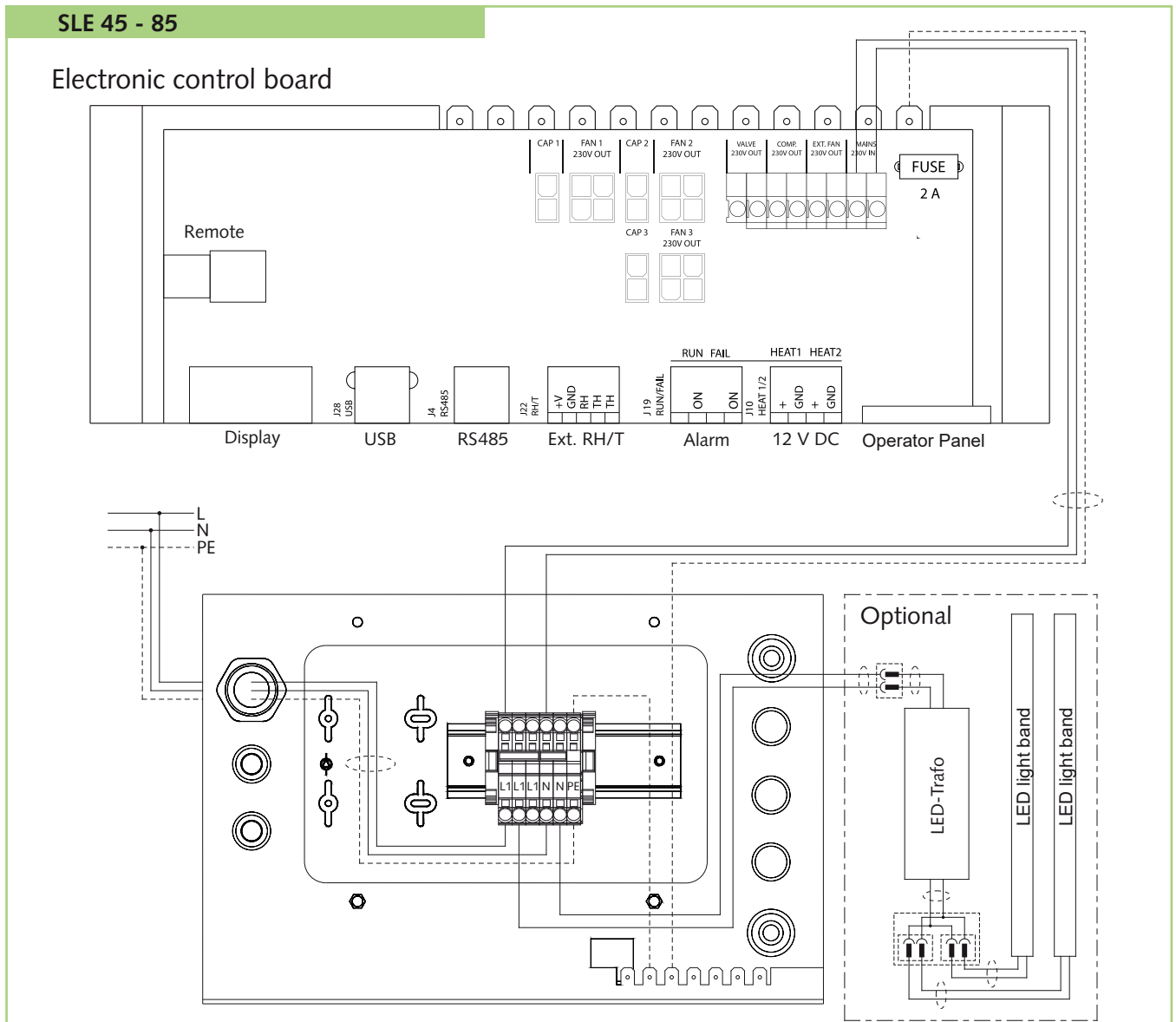

### Legend:

FAN 1 = fan motor 1  
 FAN 2 = fan motor 2  
 FAN 3 = fan motor 3  
 CAP 1 = capacitor 1  
 CAP 2 = capacitor 2  
 CAP 3 = capacitor 3

COMP. = compressor  
 VALVE = solenoid valve  
 RUN = potential-free contact  
 FAIL = potential-free contact  
 HEAT 1/2 = 12 V supply voltage for controlling relays

### Fan motors:

SLE 45 = FAN 1  
 SLE 65 = FAN 1 and FAN 2  
 SLE 85 = FAN 1, FAN 2 and FAN 3

### ⚠ CAUTION

Prior to maintenance or assembly work, the unit must be disconnected from the mains power supply.

### 💡 NOTE

A main switch should be installed at a suitable and easily accessible point in the power supply. We recommend using a mains supply line of 2.5 mm<sup>2</sup> for the units.

### 💡 NOTE

Assembly and maintenance work on the units may only be carried out by authorised and qualified technicians.

# REMKO SLE series

## Intended use

The units are designed exclusively for dehumidification purposes on the basis of their structural design and equipment.

The manufacturer shall not be liable for damage resulting from non-observance of the manufacturer's specifications, the respective local legal requirements or from arbitrary alterations to the units.

### NOTE

*Operation other than the types listed in this operating manual is prohibited.  
With non-observance, any manufacturer liability or guarantee claims are voided.*

### CAUTION

*Copyright  
Redistribution, even in part, or use of this documentation for purposes other than intended is strictly prohibited without the written authorisation of  
**REMKO GmbH & Co. KG.***

## Customer service and Guarantee

As a prerequisite for any guarantee claims to be considered, it is essential that the ordering party or its representative completes and returns the "**Certificate of guarantee**" to REMKO GmbH & Co. KG at the time when the units are purchased and commissioned.

The units were tested at the factory several times to verify their correct function.

However, if malfunctions should arise that cannot be remedied by the operator with the assistance of the troubleshooting section, please contact your specialist dealer or contractual partner.

### NOTE

*Adjustment and maintenance work may only be carried out by authorised and qualified technicians.*

## Important information concerning recycling

The units are operated with environmentally-friendly and ozone-neutral R407C refrigerant. The mixture of refrigerant and oil within the unit must be disposed of properly in accordance with the statutory or locally-applicable regulations.



## Environmental protection and recycling

### Disposing of packaging

When disposing of packaging material, please consider our environment.

Our units are carefully packed and delivered in stable cardboard transport packaging and, if applicable, on a wooden pallet. The packaging materials are environmentally-friendly and can be recycled.

By recycling packaging materials, you make a valuable contribution to the reduction of waste and conservation of raw materials. **Therefore, only dispose of packaging material at appropriate collection points.**

### Disposal of the old unit

The manufacturing process for the units is subject to continuous quality control.

Only high-grade materials are processed, the majority of which are recyclable.

You also contribute to environmental protection by ensuring that your old equipment is only disposed of in an environment friendly manner.

**Therefore, only bring the old unit to an authorised recycling business or to an appropriate collection point.**





# REMKO SLE series

## Exploded view of the unit

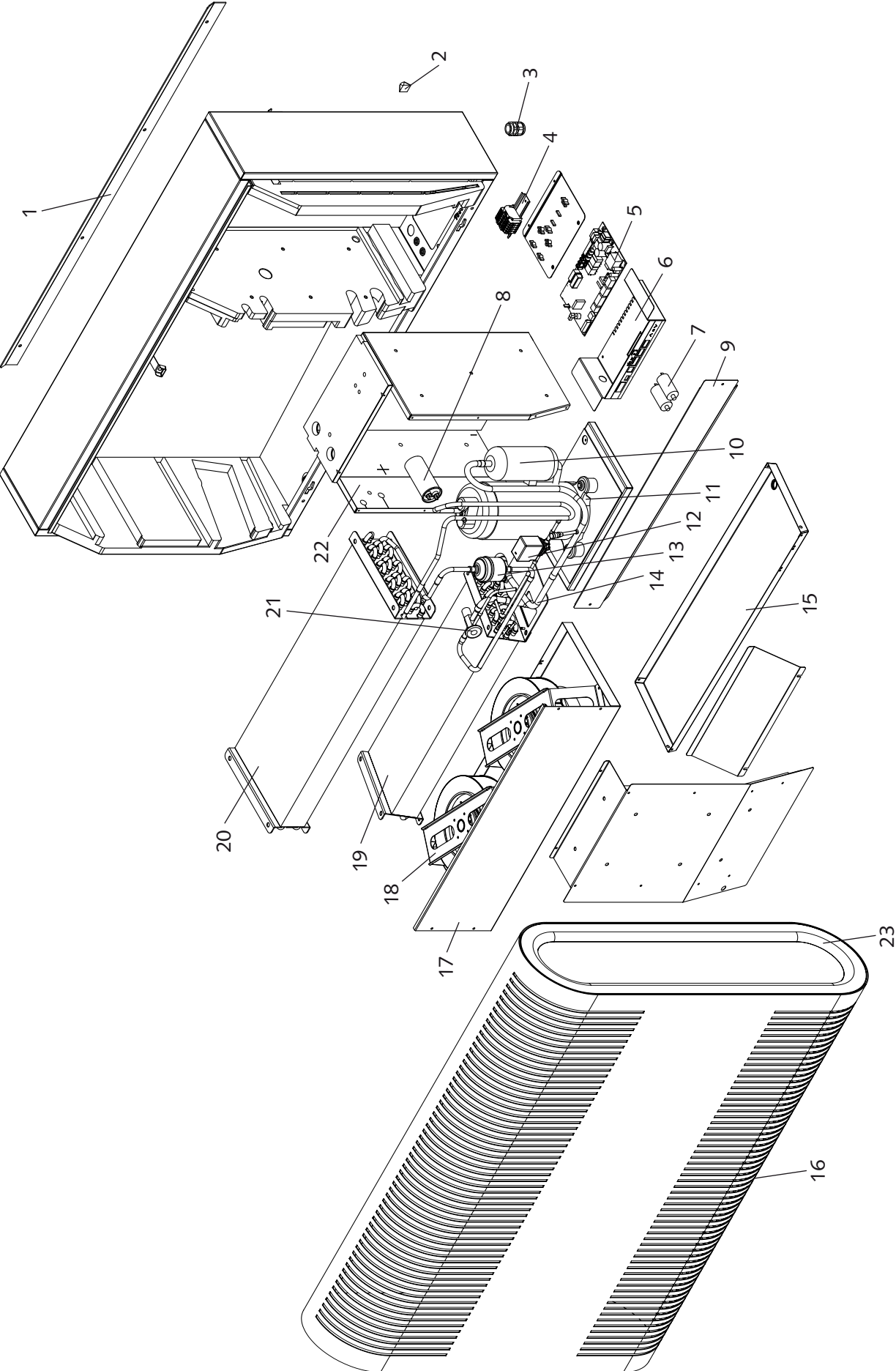

## Spare parts list

No.	Designation	SLE 45	SLE 65	SLE 85
1	Wall-mounted bracket			
2	Wall spacer			
3	Cable gland			
4	Series terminals on DIN rail			
5	Control board			
6	Holder for control board with operator panel			
7	Condenser fan			
8	Compressor capacitor			
9	Spatter guard			
10	Compressor			
11	Compressor accessories			
12	Solenoid valve			
13	Dry filter			
14	Copper piping set			
15	Condensate tray			
16	Unit panel			
16a	Unit panel (white LED)			
16b	Unit panel (RGB LED)			
17	Fan module			
18	Fan			
19	Evaporator			
20	Condenser			
21	Temperature valve			
22	Compressor insulation			
23	Side panel			
23a	White LED side panel			
23b	RGB LED side panel			
Not illustrated	White LED transformer			
Not illustrated	RGB LED transformer			
Not illustrated	RGB LED control unit			
Not illustrated	LED wireless remote control			
Not illustrated	LED operating switch			
Not illustrated	Cable with plug contact (unit side)			
Not illustrated	Strain relief			
Not illustrated	Suction filter			

EDP no. on request

When ordering spare parts, please always state the EDP no. and unit number (see name plate)!

# REMKO SLE series

## RS-485 interface

The RS-485 interface uses the Modbus RTU protocol as a slave unit. The unit does not have an address. Settings: 115200, N, 8, 1. It accepts queries for any address.

Code functions	
0x06	Present single register
0x10	Present multiple register
0x03	Read holding register

Register	Byte	Database parameters	Min	Max	Hr.	Description
2	2	Comp_state	0	1	0	Compressor status: 0 – Compressor stopped 1 – Compressor running
	3	Fan_state	0	1	0	Fan status: 0 – Fan stopped 1 – Fan running
3	4	Sole_state	0	1	0	Solenoid valve: 0 – closed 1 – open
	5	ExFan_state	0	1	0	Extractor fan status: 0 – Fan stopped 1 – Fan running
4	6	Heat1_state	0	1	0	Status HEAT 1: 0 – HEAT 1 off 1 – HEAT 1 on
	7	Heat2_state	0	1	0	Status HEAT 2: 0 – HEAT 2 off 1 – HEAT 2 on
5	8	Alarm1_state	0	1	0	Output alarm 1: 0 – Alarm output off 1 – Alarm output on
	9	Alarm2_state	0	1	0	Output alarm 2: 0 – Alarm output off 1 – Alarm output on
6	10	Evap_temp1 (decimal)	-40	100	0	Temperature of evaporator 1: Decimal: Can be used as an integer value for temperature. Fraction: Can be converted to a decimal value. To obtain the total value, use the equation for floating-point numbers: "Value = decimal + (fraction/256)"
	11	Evap_temp1 (fraction)	-40	100	0	
7	12	Evap_temp2 (decimal)	-40	100	0	Temperature of evaporator 2: Use as described above
	13	Evap_temp2 (fraction)	-40	100	0	

Register	Byte	Database parameters	Min	Max	Hr.	Description
8	14	Cond_temp1 (decimal)	-40	100	0	Condenser temperature: Use as described above
	15	Cond_temp1 (fraction)	-40	100	0	
9	16	Aux_temp (fraction)	-40	100	0	Auxiliary probe temperature: Use as described above
	17	Aux_temp (fraction)	-40	100	0	
10	18	Amb_temp (decimal)	-40	100	0	Ambient air temperature: Use as described above
	19	Amb_temp (fraction)	-40	100	0	
11	20	Amb_hum (High byte)	0	100	0	Ambient air humidity: High byte is insignificant and always contains zero. Only low byte can be used
	21	Amb_hum (Low byte)				
12	22	RH_set	40	95	40	Humidity setpoint
	23	RH_Fan	40	95	40	Humidity setpoint for extractor fan start
13	24	Temp_set (decimal)	0	36	0	Temperature setpoint: Used in the same way as Evap_temp1
	25	Temp_set (fraction)				
16	30	Fail_start	0	1	0	Status of Fail_start mode
	31	SB_mode	0	1	0	Standby mode status
17	32	DEH_mode	0	1	0	Dehumidification status
	33	Ice_mode	0	1	0	Defrosting mode
18	34	LP_mode	0	1	0	LP fault mode status
	35	Sens_mode	0	1	0	Sensor fault mode status
19	36	HP_mode	0	1	0	HP fault mode status
	37	Amb_mode	0	1	0	Ambient fault mode status
20	38	AmbT_mode	0	1	0	Ambient temperature fault mode status
	39	AmbRH_mode	0	1	0	Ambient humidity fault mode status

# REMKO SLE series

Register	Byte	Database parameters	Min	Max	Hr.	Description
21	40	SW build number (high)	0	65535	x	Software build number
	41	SW build number (low)	0			
22	42	SW version (Main version)	0	255	x	Main version number of the software
	43	SW version (Minor version)	0	255	x	Minor version number of the software
23	44	HP alarm Temp. (decimal)	0	99	60	HP faults occur when Cond_temp1 is greater than this value. Used in the same way as Evap_temp1
	45	HP alarm Temp. (fraction)				
41	80	Fan_function	0	1	0	Activate fan function in standby mode
	81					
42	82	Time_wait_fan	60	7200	3600	Waiting time until fan starts up in standby mode, if activated (seconds)
	83					
43	84	Time_run_fan	15	600	60	Fan operating time in standby mode, if activated (seconds)
	85					
44	86	RH_Fen	0	1	0	Activate/deactivate extractor fan function
	87	Service_ena	0	1	0	Activate/deactivate maintenance interval function
45	88	Service_int	0	99	0	Maintenance interval value in weeks
	89					



## USB interface

The USB interface is used for transferring data logs from the unit to a USB stick.

The unit data is saved every three hours and stored in the internal memory. Switching the status to fault mode also triggers the storage of data.

If the memory is completely full, the oldest logs are overwritten by the newest logs.

When a USB stick is inserted into the USB interface, all of the logs that have been recorded are saved in the CSV file "data\_log.csv". The data in the internal memory is not deleted as a result of this process and can therefore be transferred to several USB sticks.

The data log is saved in the form of the following parameters:

Database parameters	Size (bits)	Output text	CSV column
Work_time	32	<dd:mm:hh:ss>	Time stamp
Amb_temp	8	<Value>	T_amb
Amb_int_temp	8	<Value>	T_amb_int
Amb_ext_temp	8	<Value>	T_amb_ext
Aux_temp	8	<Value>	T_aux
Cond_temp1	8	<Value>	T_cond
Evap_temp1	8	<Value>	T_evap1
Evap_temp2	8	<Value>	T_evap2
Temp_set	8	<Value>	T_set
Amb_hum	8	<Value>	RH_amb
Amb_int_hum	8	<Value>	RH_amb_int
Amb_ext_hum	8	<Value>	RH_amb_ext
RH_set	8	<Value>	RH_set
RH_Fan	8	<Value>	ExtFanSet
Evap_temp_err	1	EVAP	Error
Cond_temp_err	1	COND	Error
Aux_temp_err	1	AUX	Error
Amb_int_err	1	AMB_INT	Error
Amb_ext_err	1	AMB_EXT	Error
SB_mode	1	SB	Mode
Startup_mode	1	STARTUP	Mode
DEH_mode	1	DEH	Mode
Ice_mode	1	ICE	Mode
LP_mode	1	LP	Mode
HP_mode	1	HP	Mode
Sens_mode	1	SENS	Mode
AmbT_mode	1	AMBT	Mode
AmbRH_mode	1	AMBRH	Mode
Service_ena	1	ENABLED	Mode

# REMKO SLE series



## Maintenance log

Unit type: ..... Unit number: .....

	1	2	3	4	5	6	7	8	9	10	11	12	13	14	15	16	17	18	19	20
Unit cleaned - outside -																				
Unit cleaned - inside -																				
Condenser cleaned																				
Evaporator cleaned																				
Fan function checked																				
Unit checked for damage																				
Safety devices checked																				
All fastening screws checked																				
Electrical safety check																				
Test run																				

Comments: .....

.....

.....

.....

1. Date: ..... ..... Signature	2. Date: ..... ..... Signature	3. Date: ..... ..... Signature	4. Date: ..... ..... Signature	5. Date: ..... ..... Signature
6. Date: ..... ..... Signature	7. Date: ..... ..... Signature	8. Date: ..... ..... Signature	9. Date: ..... ..... Signature	10. Date: ..... ..... Signature
11. Date: ..... ..... Signature	12. Date: ..... ..... Signature	13. Date: ..... ..... Signature	14. Date: ..... ..... Signature	15. Date: ..... ..... Signature
16. Date: ..... ..... Signature	17. Date: ..... ..... Signature	18. Date: ..... ..... Signature	19. Date: ..... ..... Signature	20. Date: ..... ..... Signature

Unit to be maintained only by authorised specialists in accordance with the statutory regulations.

## Technical data

Series		SLE 45	SLE 65	SLE 85
Daily dehumidification capacity at 30 and 80 % RH	Litres/day	47	78	104
Daily dehumidification capacity at 30 and 60% RH	Litres/day	35.5	56.2	78.8
Operational temperature range	°C	10 to 36		
Usable humidity range	% RH	40 to 100		
Air volume	m <sup>3</sup> /h	400	680	900
Power supply	V/Hz	230/1~/50		
Max. power consumption	kW	0.9	1.5	1.8
Max. rated current consumption	A	3.8	6.6	8
Max. switching voltage from RUN and FAIL contact	V	50	50	50
Max. switching current from RUN and FAIL contact	A	0.5	0.5	0.5
HEAT contact voltage	V	12	12	12
Maximum current limit of a HEAT contact	mA	60	60	60
Refrigerant <sup>1)</sup>		R407C		
Refrigerant quantity	kg	0.7	0.9	1.2
Sound pressure level L <sub>pA</sub> 1m <sup>2)</sup>	dB (A)	46	47	50
Depth	mm	335	335	335
Width	mm	1015	1165	1500
Height	mm	816	816	816
Weight	kg	62	76	103
IP enclosure class		X4	X4	X4
EDP no.		616450	616650	616850

1) Contains greenhouse gas according to Kyoto protocol

2) Noise level measurement DIN 45635 - 13 - KL 3 carried out at duct openings

Light equipment		White LED	RGB LED
Operating voltage	V DC	12	12
Power	W	28	28
Average service life	h	25,000	
Lumen	Lumen	approx. 400 - 2150	
Lamp		White LED	RGB LED

# Energy label

## White LED

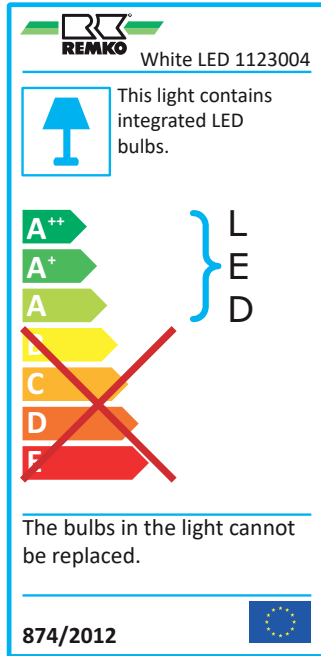

## RGB LED

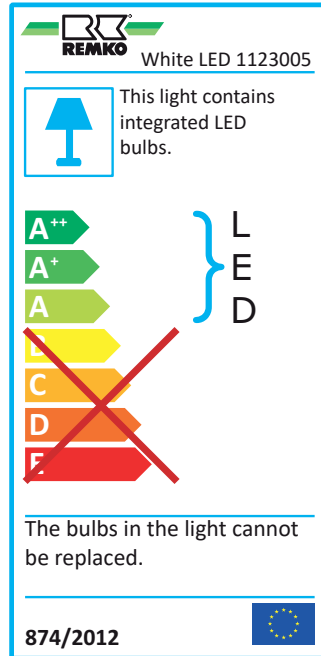

# Characteristic curves

Capacity diagram SLE 45

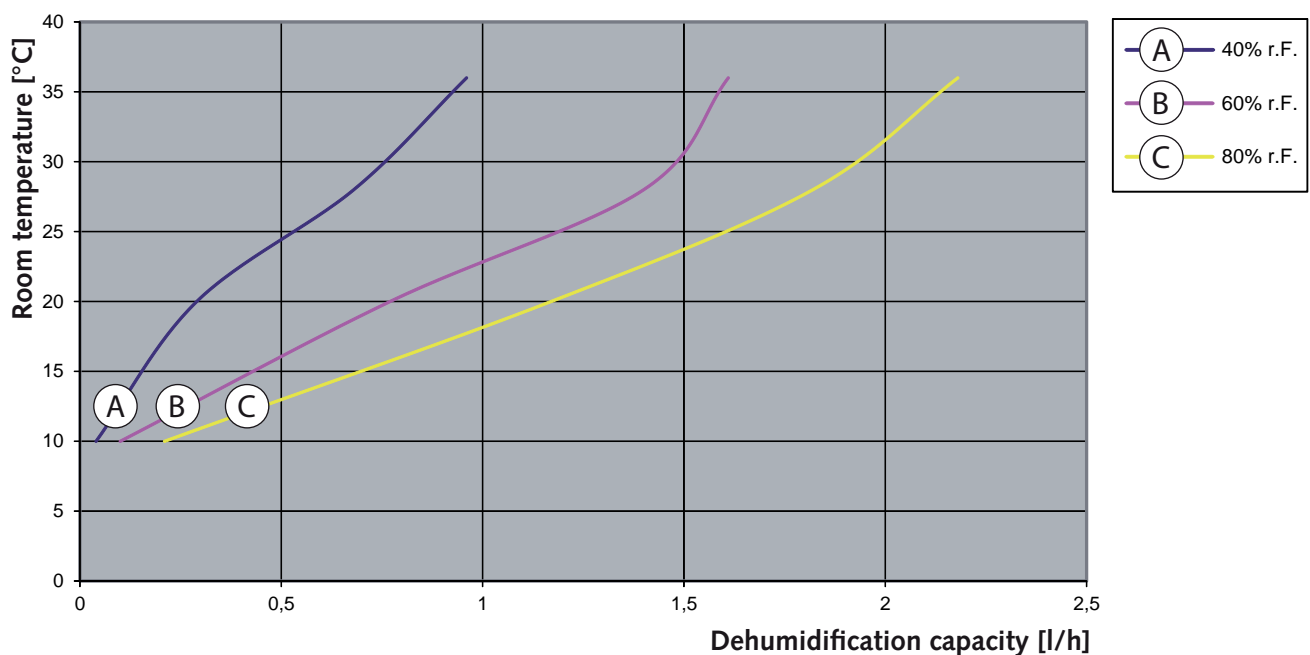

### Capacity diagram SLE 65

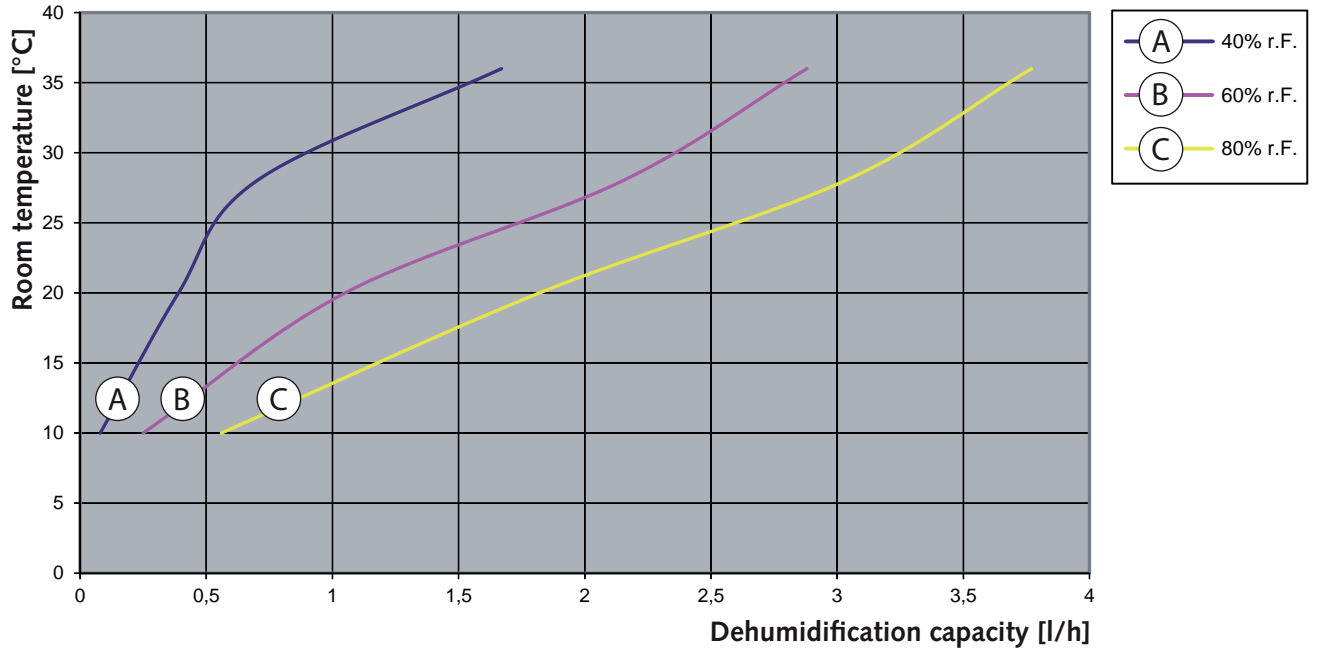

### Capacity diagram SLE 85

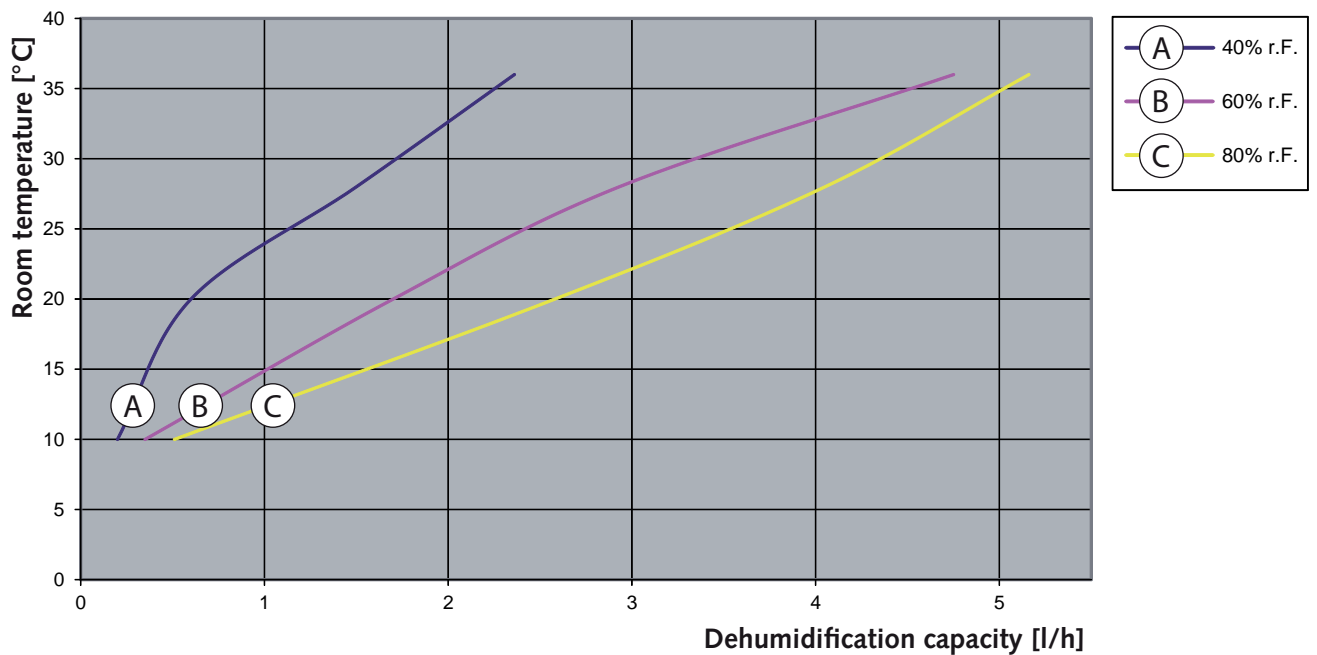

# REMKO SLE series

## Notes

Blank lined area for notes, consisting of 18 horizontal green bars.



# REMKO INTERNATIONAL

*... and also right in your neighbourhood!  
Take advantage of our experience and advice*



## **REMKO GmbH & Co. KG** **Air conditioning and heating technology**

Im Seelenkamp 12	D-32791 Lage
Postfach 1827	D-32777 Lage
Telephone	+49 5232 606-0
Fax	+49 5232 606-260
E-mail	info@remko.de
Internet	www.remko.de

### **Consulting**

Thanks to intensive training, our consultants are always completely up-to-date when it comes to technical expertise. This has given us the reputation of being more than just an excellent, reliable supplier: REMKO, a partner who helps to solve problems.

### **Sales**

REMKO offers not just a well established sales network both nationally and internationally, but also has exceptionally highly-qualified sales specialists. REMKO employees in the field are more than just sales people: above all, they must be advisers to our customers in air conditioning and heating technology.

### **Customer service**

Our units operate precisely and reliably. However, in the event of a malfunction REMKO customer service is quickly on the scene. Our comprehensive network of experienced dealers guarantees quick and reliable service.

