

# Bathroom extract fan

## Axial flow fans

# SILENT-200 DESIGN



### Description

- Elegant design
- Very low noise level: **35 dB(A)**
- Low consumption: **16W**
- **IP 45**
- Thermal protection
- Backdraft shutter
- 3 additional bar lights (red, green, yellow)
- Versions with electronic timer (CRZ) or adjustable hygostat (CHZ)

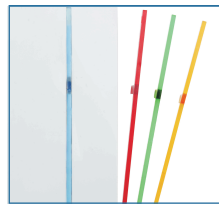

3 additional bar lights

### Technical characteristics

Model	maximum absorbed power (W)	Voltage (V-Hz)	Sound pressure level* dB(A)	Air volume (m3/h)	Insulation IP	Weight (kg)
SILENT-200 DESIGN	16	230-50	35	175	II - 45	0,88

Sound pressure level measured at 3 m at free field conditions

	CZ	CRZ	CHZ
Pilot light	x	x	x
Backdraft shutter	x	x	x
Adjustable Timer		x	x
Adjustable hygostat			x
Ball bearings	x	x	x
3 additional bar lights	x	x	x

### Dimensions (mm)

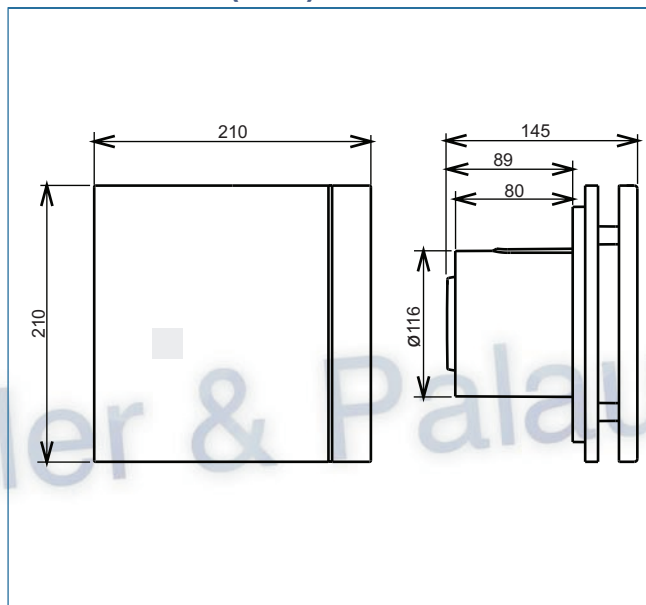

### Performance curve

