



Standard



With by-pass (BP)  
 (only for horizontal  
 installation)

Static (without fan) high efficiency heat recovery units (up to 92%), with a low profile and light weight enabling them to be installed in false ceilings, designed to work with low consumption fans. Cabinet made of galvanised sheet steel with 10 mm thick polyurethane foam insulation (M1), totally hermetic, rubber gaskets inlet and outlet circular duct connections. Easy maintenance through access hatch. High-efficiency PVC counterflow-type heat exchanger. Condensation drain and inlet and outlet filters (G2 grade) that can be changed without the use of tools.

**CADS-HE BP models**

Incorporating a motorised by-pass. The by-pass enables part of the air extracted not to pass through the heat exchanger, when it is desired to cool the premises (with a lower outside temperature than the inside). The by-pass is reversible, so it can adapt to different airflow layouts, supplying added or extracted air according to the configuration of the ducting system.

**Additional information**

G4 filters, as an accessory.



**Easy maintenance**  
 Cover for quick access to the heat exchanger and filters, to facilitate their cleaning or replacement.



**Models with by-pass**  
 BP models with a reversible by pass, which enables part of the extracted air not to pass through the heat exchanger. Works with a motorised damper.

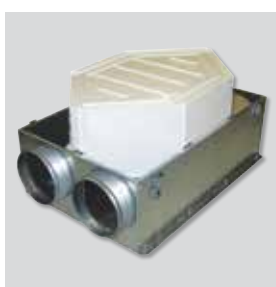

**Heat exchanger**  
 Counter flow high efficiency heat exchanger.

**Specific applications**



Multi dwelling blocks



Heat recovery units

### TECHNICAL CHARACTERISTICS

Model	Efficiency	Maximum airflow (m <sup>3</sup> /h)
CADS-HE 150	82 - 92 %	300
CADS-HE 160	82 - 92 %	300
CADS-HE BP 150	82 - 92 %	300
CADS-HE BP 160	82 - 92 %	300

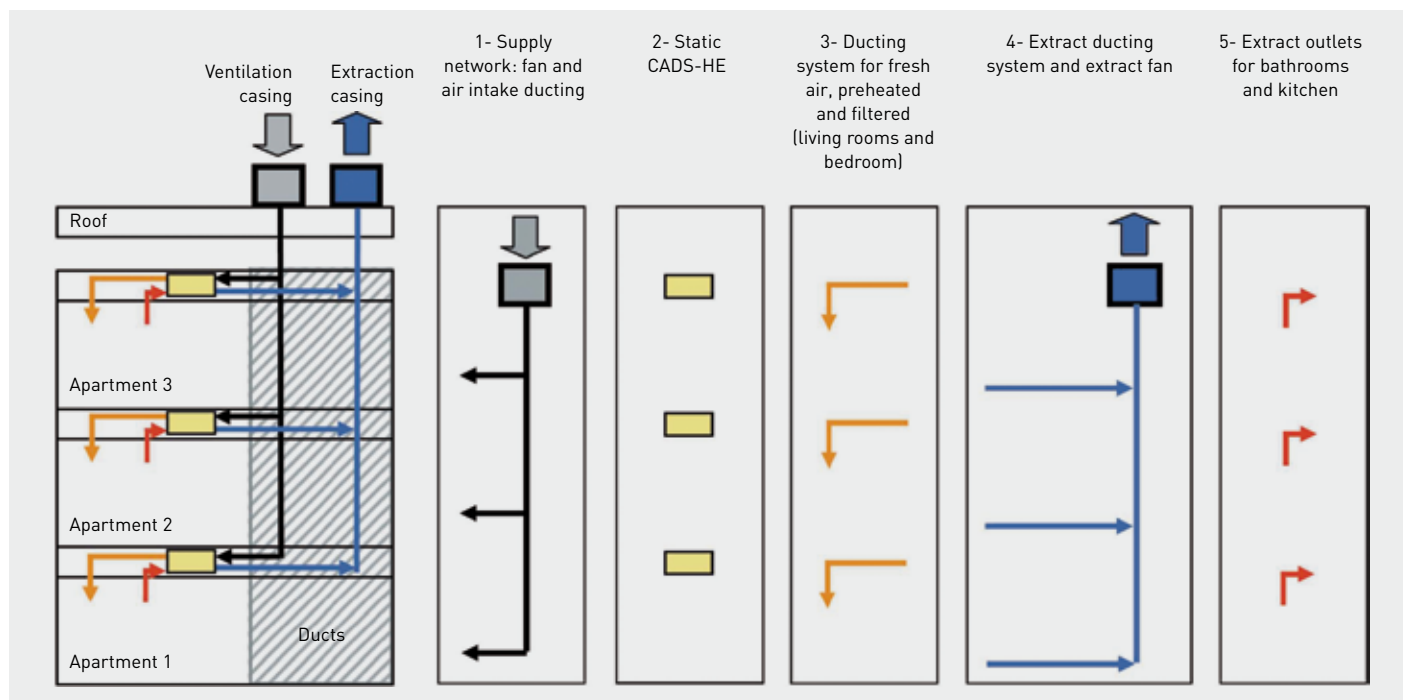

### PERFORMANCE CURVES

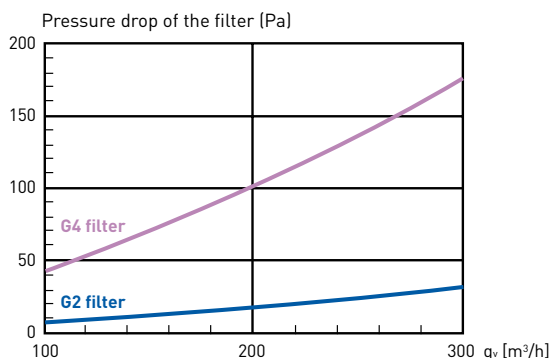
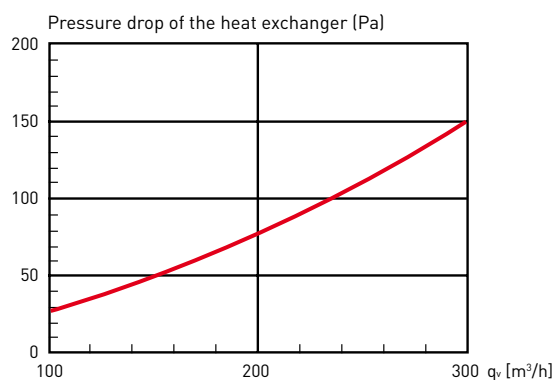
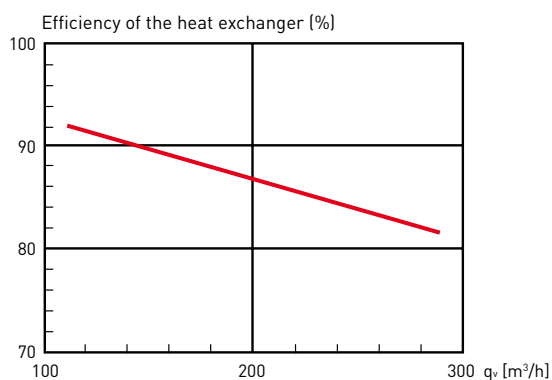

**DIMENSIONS (mm)**

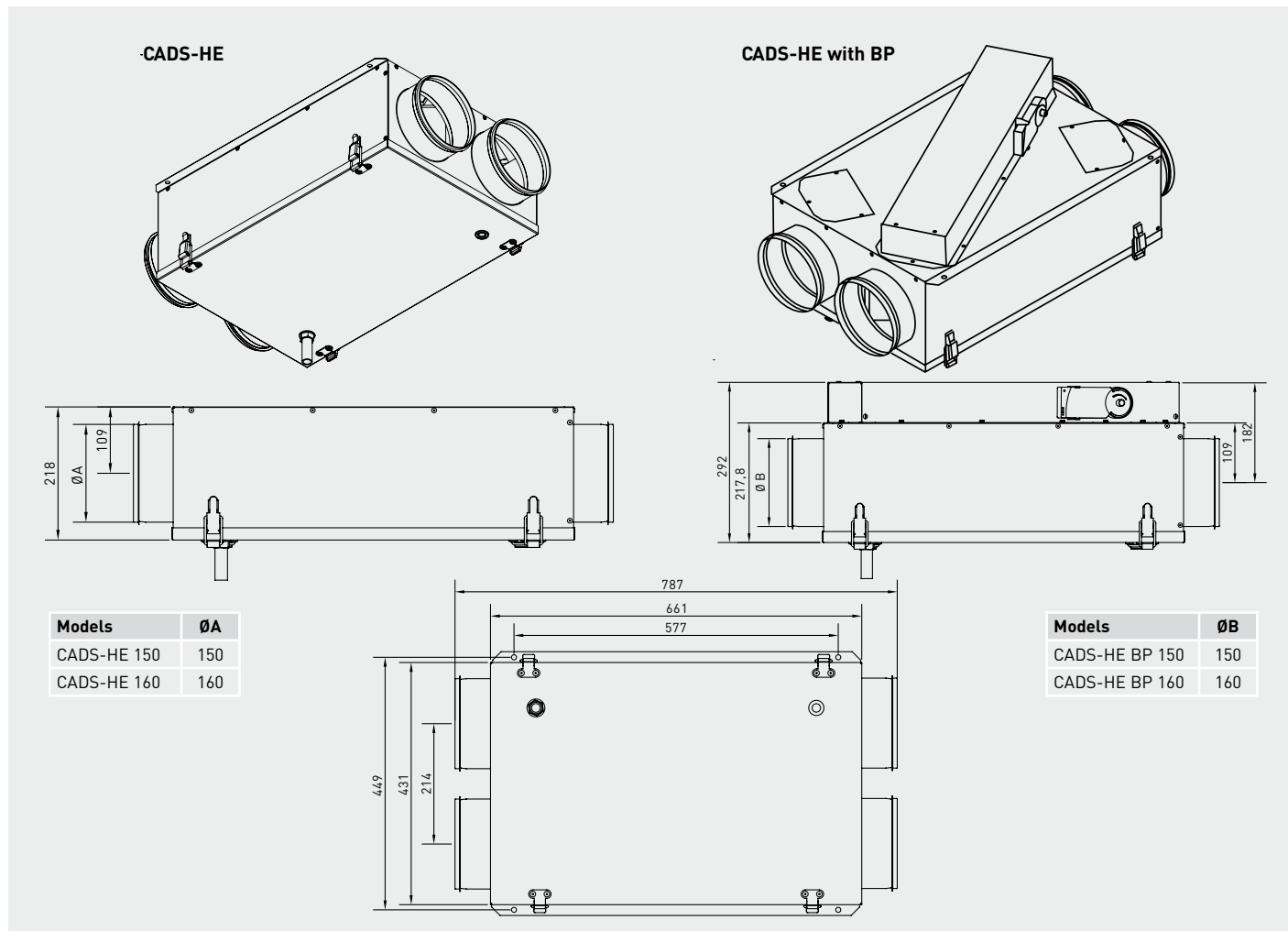

**ACCESSORIES**

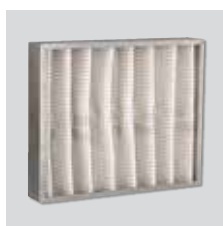

**G4 filter**  
 G4 foam filter  
 measuring  
 255x195 mm.