

Extraction arm

## KUA-160/H /S /ATEX

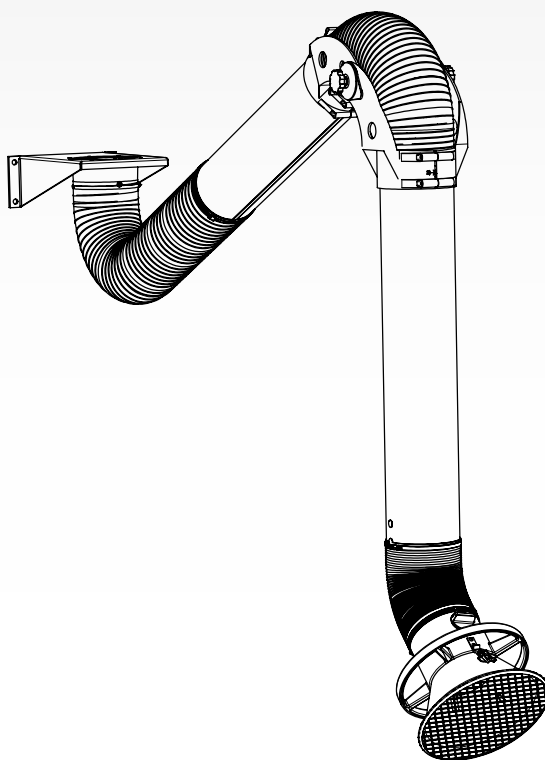

EN

Installation and user manual

---

---

## TABLE OF CONTENTS

PREFACE.....	2
1 INTRODUCTION.....	2
2 PRODUCT DESCRIPTION .....	3
3 SAFETY .....	3
4 INSTALLATION .....	4
5 USE .....	8
6 MAINTENANCE .....	9
7 TROUBLESHOOTING .....	9
8 SPARE PARTS .....	9
9 DISPOSAL.....	9
CE DECLARATION.....	10

### EN | ORIGINAL INSTRUCTION

All rights reserved. The information given in this document has been collected for the general convenience of our clients. It has been based on general data pertaining to construction material properties and working methods known to us at the time of issue of the document and is therefore subject at any time to change or amendment and the right to change or amend is hereby expressly reserved. The instructions in this publication only serve as a guideline for installation, use, maintenance and repair of the product mentioned on the cover page of this document. This publication is to be used for the standard model of the product of the type given on the cover page. Thus the manufacturer cannot be held responsible for any damage resulting from the application of this publication to the version actually delivered to you. This publication has been written with great care. However, the manufacturer cannot be held responsible, either for any errors occurring in this publication or for their consequences.

*To improve comprehension for people whose first language is not English, we have written parts of this manual in Simplified Technical English (STE). STE is a controlled language originally developed for aerospace industry maintenance manuals. It offers a carefully limited and standardized subset of English, along with specific writing rules.*









## PREFACE

### Using this manual

This manual is intended to be used as a work of reference for professional, well trained and authorised users to be able to safely install, use, maintain and repair the product mentioned on the cover of this document.

### Pictograms and symbols

The following pictograms and symbols are used in this manual:

	<b>TIP</b> Suggestions and recommendations to simplify carrying out tasks and actions.
	<b>ATTENTION</b> A remark brings additional information for the user. A remark brings possible problems to the user's attention.
	<b>CAUTION!</b> Procedures, if not carried out with the necessary caution, could damage the product, the workshop or the environment.
	<b>WARNING!</b> Procedures which, if not carried out with the necessary caution, may damage the product or cause serious personal injury.
	<b>WARNING!</b> Fire hazard! Important warning to prevent fire.
	<b>WARNING!</b> Explosion hazard! Important warning to prevent explosions.
	<b>Personal protective equipment (PPE)</b> Instruction to use respiratory protection when you do service, maintenance and repair jobs, as well as during functional testing. We recommend to use a half-face respirator according to EN 149:2001 + A1:2009, class FFP3 (Directive 89/686/EEC).
	<b>Personal protective equipment (PPE)</b> Instruction to use protective gloves when you do service, maintenance and repair jobs.

### Text indicators

Listings indicated by "-" (hyphen) concern enumerations.  
Listings indicated by "•" (bullet point) describe steps to perform.

## 1 INTRODUCTION

### 1.1 Identification of the product

The identification plate contains, among other things, the following data:

- product name
- serial number



### 1.2 General description

The KUA-160 is an extraction arm with an external middle hinge. The removable hood has a safety mesh. The arm is fitted with a control valve and is 360° rotatable<sup>1</sup>. The hood is 90° movable in four directions.

The KUA-160 arm is available in four different types:

- type **H**: for hanging mounting (wall bracket included)
- type **S**: for standing mounting (e.g. on a mobile unit)
- type **ATEX**: approved for use in explosive environments Zone 22; marking EX II 3D (for hanging mounting only)<sup>2</sup>

1. KUA-160 ATEX: 359° rotatable due to the litz wire

2. In accordance with TRGS 727 & ATEX Directive 2014/34/EU

- type **H-D**: for hanging mounting, with sealed shut-off valve

### 1.3 Options and accessories

FlowGuard	Airflow sensor
-----------	----------------

### KUA-160 all types (except for ATEX versions)

S-100	Manual on/off switch for hood mounting
LL-5.5/24-160	Manual on/off switch, incl. LED working light

### 1.4 Product combinations

You can use the KUA-160 with the following products:

#### 1.4.1 KUA-160/2H | 3H | 4H (incl. ATEX versions)

FUA-1800	0,55 kW (0.75 HP)	Extraction fan
FUA-2100	0,75 kW (1 HP)	
PA-110/160	1,1 m (3½ ft)	Stanchion
PA-220/160	2,2 m (7 ft)	
FM-15/160	1,5 m (5 ft)	Extension crane (type FlexMax)
FM-25/160	2,5 m (8¼ ft)	
FM-35/160	3,5 m (11½ ft)	
FM-45/160	4,5 m (15 ft)	
ERC		Extraction rail
SLE-30	3 m (9¾ ft)	Extension hose

#### 1.4.2 KUA-160/2S | 3S | 4S

MobileGo	Mobile welding fume extractor	
MobilePro	Mobile welding fume extractor	
PA-110/160	1,1 m (3½ ft)	Stanchion [+ additional wall bracket, art. no. 0000101537]
PA-220/160	2,2 m (7 ft)	

### 1.5 Technical specifications

Physical dimensions and properties	
Length:	
- KUA-160/2	- 2 m (6½ ft)
- KUA-160/3	- 3 m (9¾ ft)
- KUA-160/4	- 4 m (13 ft)
Diameter:	
- tubes	- Ø 160 mm (6¼ in.)
- hood opening	- Ø 300 mm (12¾ in.)
Material of tubes	aluminium
Material of hoses:	
- type <b>H</b> and <b>S</b>	- PVC with spring steel wire
- type <b>ATEX</b>	- polyethylene with copper coated spring steel wire
Weight:	
- KUA-160/2	- 14 kg (31 lbs)
- KUA-160/3	- 15 kg (33 lbs)
- KUA-160/4	- 17 kg (37½ lbs)
- wall bracket ( <b>H</b> types)	- 4 kg (9 lbs)
Performance	
Recommended airflow	800-1200 m³/h (470-710 CFM)
- min. airflow	800 m³/h (470 CFM)

### 1.6 Working reach

Refer to Fig. I on page 11.

### 1.7 Pressure drop

Refer to Fig. II on page 11.

 Refer to the available product data sheet for detailed product specifications.

## 1.8 Ambient and process conditions

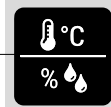

Process temperature:	
- min.	- 5°C (41°F)
- nom.	- 20°C (68°F)
- max.	- 70°C (158°F)
Max. relative humidity	90%
Outdoor use allowed	no

## 2 PRODUCT DESCRIPTION

### 2.1 Components

The product consists of the following main components and elements:

Fig. 2.1

- A Wall bracket<sup>3</sup>
- B Rotating flange
- C Hose
- D Inner tube
- E Middle hinge
- F Outer tube
- G Sealed shut-off valve<sup>4</sup>
- H Hood incl. control valve

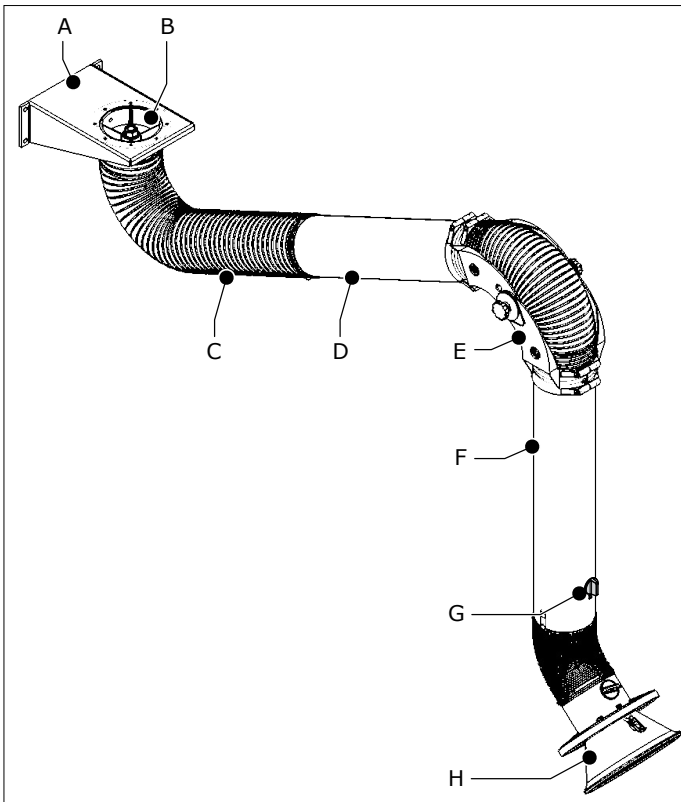

Fig. 2.1 Main components and elements

#### 2.1.1 KUA-160 ATEX

KUA-160 ATEX arms are suitable for use in potentially explosive environments. They comply with ATEX directives due to:

- antistatic hoses instead of standard hoses
- litz wires that interconnect the metal parts of the arm

3. Only applicable for **H** types

4. Only applicable for **H-D** types

## 2.2 Operation

The welding fume is extracted through the hood of the arm by a single or central fan. The extraction arm discharges the polluted air to an extraction duct with filter unit or directly to the atmosphere.

The hood of the arm is fitted with a control valve to shut off or regulate the airflow. The valve is mostly used when several extraction arms are integrated in a line installation; in such configurations closing the valve prevents the loss of costly heated air.

## 3 SAFETY

### General



The manufacturer does not accept any liability for damage to the product or personal injury caused by ignoring of the safety instructions in this manual, or by negligence during installation, use, maintenance, and repair of the product mentioned on the cover of this document and any corresponding accessories. Specific working conditions or used accessories may require additional safety instructions. Immediately contact your supplier if you detect a potential danger when using the product.

**The user of the product is always fully responsible for observing the local safety instructions and regulations. Observe all applicable safety instructions and regulations.**

### User manual

- Everyone working on or with the product, must be familiar with the contents of this manual and must strictly observe the instructions therein. The management should instruct the personnel in accordance with the manual and observe all instructions and directions given.
- Do not change the order of the steps to perform.
- Keep the manual with the product.

### Users

- The use of this product is exclusively reserved to authorised, trained and qualified users. Temporary personnel and personnel in training can only use the product under supervision and responsibility of skilled engineers.
- Stay alert and keep your attention to your work. Do not use the product when you are under the influence of drugs, alcohol or medicine.
- The product is not to be used by children or persons with reduced physical, sensory or mental capabilities, or lack of experience and knowledge, unless they have been given supervision or instruction.
- Children must be supervised not to play with the product.

### Intended use<sup>5</sup>

The product has been designed exclusively for extracting fumes and particles which are released during the most common welding and cutting processes. Using the product for other purposes is considered contrary to its intended use. The manufacturer accepts no liability for any damage or injury resulting from such use. The product has been built in accordance with state-of-the-art standards and recognised safety regulations. Only use this product when in technically

5. "Intended use" as explained in EN-ISO 12100-1 is the use for which the technical product is suited as specified by the manufacturer, inclusive of his directions in the sales brochure. In case of doubt it is the use which can be deduced from the construction, the model and the function of the technical product which is considered normal use. Operating the machine within the limits of its intended use also involves observing the instructions in the user manual.

perfect condition in accordance with its intended use and the instructions explained in the user manual.

### Technical specifications

Do not change the specifications given in this manual.

### Modifications

Modification of (parts of) the product is not allowed.



### Product combinations

If the product is used in combination with other products or machines, the safety instructions in the documentation of these products also apply.

### Installation

- The installation of this product is exclusively reserved to authorised, trained and qualified engineers.
- During installation, always use Personal Protective Equipment (PPE) to avoid injury. This also applies to persons who enter the work area during installation.
- Use sufficient climbing gear and safety guards when working on a higher level than 2 metres (local restrictions may apply).
- Do not install the product in front of entrances and exits which must be used for emergency services.
- Mind any gas and water pipes and electric cables.
- Make sure that the workspace is well illuminated.
- Stay alert and keep your attention to your work. Do not install the product when you are under the influence of drugs, alcohol or medicine.
- Air containing particles such as chromium, nickel, beryllium, cadmium, lead etc., should never be recycled. This air must always be brought outside the working area.

### Use



	<p><b>WARNING!</b> Fire hazard! Do <b>not</b> use the product for:</p> <ul style="list-style-type: none"> <li>- polishing applications in combination with grinding, welding or any other application that generate sparks (fibers from polishing or abrasive flap disks are highly flammable and pose a high risk of filter fires when exposed to sparks)</li> <li>- arc-air gouging</li> <li>- extracting flammable, glowing or burning particles or solids or liquids</li> <li>- extracting of aggressive fumes (such as hydrochloric acid) or sharp particles</li> <li>- sucking cigarettes, cigars, oiled tissues, and other burning particles, objects, and acids</li> </ul>
	<p><b>WARNING!</b> Explosion hazard! Do <b>not</b> use the product for explosion-hazardous applications, e.g.:</p> <ul style="list-style-type: none"> <li>- aluminium laser cutting</li> <li>- grinding aluminium and magnesium</li> <li>- explosive environments or explosive substances/gases</li> </ul> <p><i>This warning does not apply to KUA-160 ATEX arms</i></p>
	<p><b>WARNING!</b> Do <b>not</b> use the product for:</p> <ul style="list-style-type: none"> <li>- extraction of hot gases (more than 70°C/158°F continuously)</li> <li>- flame spraying</li> <li>- extraction of cement, saw dust, wood dust etc.</li> </ul>

- Inspect the product and check it for damage. Verify the functioning of the safety features.
- During use, always use Personal Protective Equipment (PPE) to avoid injury. This also applies for persons who enter the work area.

- Check the working environment. Do not allow unauthorised persons to enter the working environment.
- Protect the product against water and humidity.
- Make sure the room is always sufficiently ventilated; this applies especially to confined spaces.
- Make sure that the workshop, in the vicinity of the product, contains sufficient approved fire extinguishers (suitable for fire classes ABC).

### Service, maintenance and repairs

- Obey the maintenance intervals given in this manual. Overdue maintenance can lead to high costs for repair and revisions and can render the guarantee null and void.
- Always use Personal Protective Equipment (PPE) to avoid injury. This also applies for persons who enter the work area.
- Make sure the room is sufficiently ventilated.
- Use tools, materials, lubricants and service techniques which have been approved by the manufacturer. Never use worn tools and do not leave any tools in or on the product.
- Safety features which have been removed for service, maintenance or repairs, must be put back immediately after finishing these jobs and it must be checked that they still function properly.
- Use sufficient climbing gear and safety guards when working on a higher level than 2 metres (local restrictions may apply).
- Clean the area afterwards.

	<p><b>ATTENTION</b> Service, maintenance and repairs must be performed in accordance with directive TRGS 560 and TRGS 528 by authorised, qualified and trained persons (skilled) using appropriate work practices.</p>
	<p><b>Personal protective equipment (PPE)</b> Wear respiratory protection and protective gloves during service, maintenance and repairs.</p>

## 4 INSTALLATION

### 4.1 Tools and requirements

You need the following tools and requirements to install the product:

- basic tools



### 4.2 To be sourced locally

You need the following material to install the product:

- wall mounting hardware<sup>6</sup>



### 4.3 Unpacking

Make sure that the product is complete. The package contains:

- extraction arm (pre-assembled)
- rotating flange
- arm swivel ring, incl. rubber collar
- extraction hood
- hood collar with safety mesh
- washer M20



Additionally for "H" types:

- wall bracket (with integrated rotating flange)
- hexagon bolt M6x25 (4)

If parts are missing or damaged, contact your supplier.

6. The type of hardware depends on the wall type

 There are different ways to install the KUA arm. Fig. III on page 11 gives a summary of the relevant paragraphs per arm type (specifically H, ATEX and S) and the preferred mounting sequence.

For mounting of the KUA-160/H (hanging; including ATEX):

- proceed with paragraph 4.4

For mounting of the KUA-160/S (standing):

- proceed with paragraph 4.5

#### 4.4 Mounting of the KUA-160/H (including ATEX)

 For mounting examples, refer to Fig. IV on page 11.

For mounting on the **wall** or on a **mounting structure**:

- proceed with paragraph 4.4.1

For mounting on a **stanchion** (PA):

- proceed with paragraph 4.4.2

For mounting on an **extension crane** (FlexMax):

- refer to the instruction sheet that is supplied with the FlexMax
- subsequently: proceed with paragraph 4.4.3

##### 4.4.1 Wall mounting

 **WARNING!** Before you install the product, make sure that the wall or mounting structure is strong enough. Refer to paragraph 1.5 for the weight of the product.

 Refer to Fig. VII on page 12 for the dimensions and mounting measurements of the wall bracket.

The package contains no mounting hardware for the wall bracket, since the required mounting hardware depends on the wall type. You can mount the wall bracket on e.g.:

- A a thin brick or concrete wall (min. thickness 100 mm), with four threaded rods M10;
- B a thick brick or concrete wall, with four cotter bolts M10x120x60;
- C a steel profile (e.g. H-profile), with four threaded rods M10. For this purpose two square tubes (30x30x3 mm) need to be mounted to prevent bending.

Fig. 4.1

- Install the wall bracket to the wall or mounting structure.

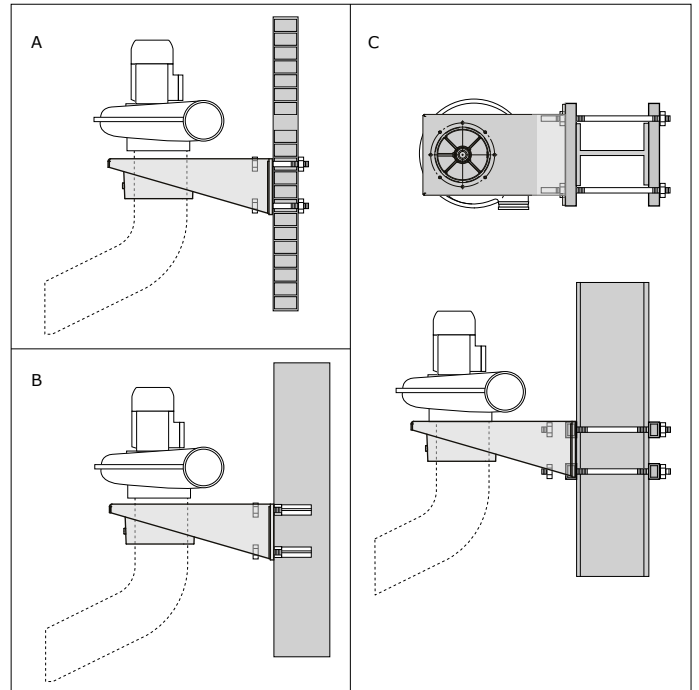

Fig. 4.1 Mounting of the wall bracket

For mounting of the arm to the wall bracket:

- proceed with paragraph 4.4.3

##### 4.4.2 Mounting on a stanchion

The stanchions PA-110/160 and PA-220/160 are suitable for several mounting positions:

Mounting to/on	Position
Floor	vertical
Ceiling	
Wall	horizontal

Recommended mounting hardware:

Mounting of:	Hardware:
Stanchion on concrete floor	Anchor bolts
Stanchion to the ceiling	Anchor bolts
Stanchion to the wall	Depends on the wall type (also refer to paragraph 4.4.1)
Wall bracket to the stanchion	4x bolt M12x30 with 4x locknut M12

Fig. 4.2

- Determine the position of the stanchion.
- Install the mounting plate accordingly.
- Install the wall bracket to the stanchion.

 Refer to Fig. VI on page 12 for detailed mounting instructions of:

- the mounting plate to the stanchion
- the wall bracket to the mounting plate

- Install the stanchion to the floor, wall or ceiling.

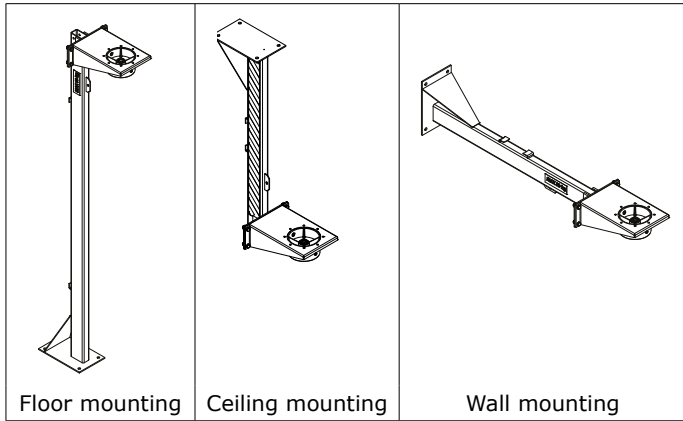

Fig. 4.2 Stanchion (PA)

For mounting of the arm to the wall bracket:

- proceed with paragraph 4.4.3

#### 4.4.3 Arm mounting

**TIP**  
Do a balance check of the arm before you fasten the hoses. Refer to paragraph 6.2.

Fig. 4.3

- Remove the locknut M20 (A) from the hinge rod (E).
- Move the hose clamp (F) and the arm swivel ring (incl. rubber collar) (D) over the hinge rod (E).
- Put the washer M20 (C) on the arm swivel ring (D).
- Put the hinge rod (E) in the rotating flange (B).
- Put the hose (G) over the arm swivel ring (D).
- Use the rubber collar to make the connection airtight.
- Attach the hose (G) to the swivel ring (D) with the hose clamp (F).
- Put the locknut M20 (A) on the hinge rod (E) and tighten it.
- Install the assembly to the wall bracket with the 8 bolts M6x25 + washers M6.

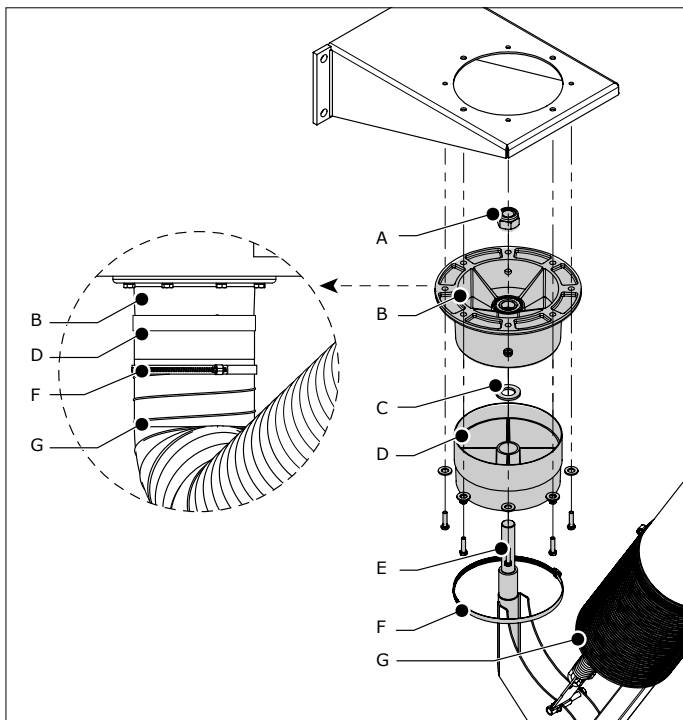

Fig. 4.3 Mounting of the arm

For mounting of the hood:

- refer to paragraph 4.6

In case of a KUA-160/H ATEX:

- subsequently proceed with paragraph 4.7

#### 4.4.4 Fan mounting

To install an extraction fan<sup>7</sup> on the arm, do the following.

Fig. 4.4

- Put the fan on the wall bracket.
- Insert 4 bolts M6x25<sup>8</sup> through the bottom of the wall bracket into the cage nuts of the fan housing.
- Fasten the bolts securely.

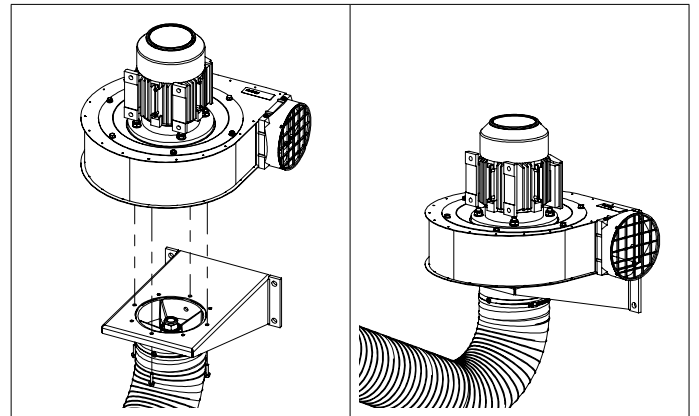

Fig. 4.4 Mounting of the fan

#### 4.5 Mounting of the KUA-160/S

For mounting examples, refer to Fig. V on page 11.

For mounting on a **stanchion (PA)**:

- proceed with paragraph 4.5.1

For mounting on a **wall bracket**:

- proceed with paragraph 4.5.2

For mounting on a **mobile unit**:

- proceed with paragraph 4.5.3

##### 4.5.1 KUA-160/S on a stanchion

Fig. 4.5

- Disassemble the rotating flange from the wall bracket and change the position from bottom to top.

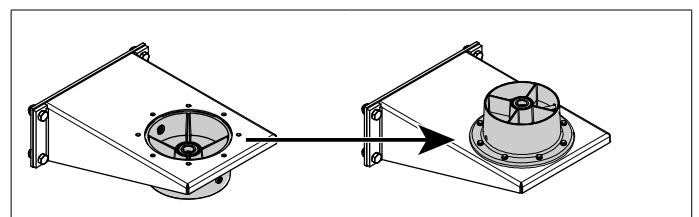

Fig. 4.5 Position of the rotating flange

7. Suitable types: refer to paragraph 1.4

8. The bolts are supplied with the arm

For mounting of the wall bracket to the stanchion:

- proceed with paragraph **4.4.2**
- subsequently: proceed with the instructions of Fig. 4.7 (paragraph **4.5.3**)

#### 4.5.2 KUA-160/S on a wall bracket

For mounting of the arm to a wall bracket:

- proceed with the instructions of Fig. 4.5 (paragraph **4.5.1**)
- subsequently: proceed with the instructions of Fig. 4.7 (paragraph **4.5.3**)

#### 4.5.3 KUA-160/S on a mobile unit



#### TIP

Do a balance check of the arm before you fasten the hoses. Refer to paragraph 6.2.

Fig. 4.6

- Install the rotating flange (C) on the filter unit with the 8 bolts M6x25 (A) + washers M6 (B).

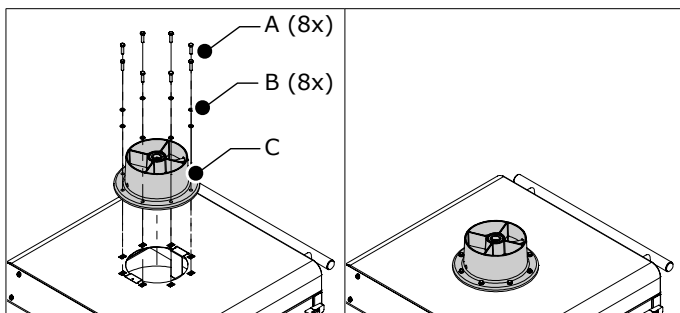

Fig. 4.6 Rotating flange

Fig. 4.7

- Move the hose clamp (C) and the arm swivel ring (incl. rubber collar) (D) over the hinge rod (B).
- Put the washer M20 (E) on the rotating flange (F).
- Put the hinge rod (B) in the rotating flange (F).
- Put the hose (A) over the arm swivel ring (D).
- Use the rubber collar to make the connection airtight.
- Attach the hose (A) to the swivel ring (D) with the hose clamp (C).



#### ATTENTION!

Make sure to install the washer M20 (E) between the rotating flange and the swivel ring to avoid damage.

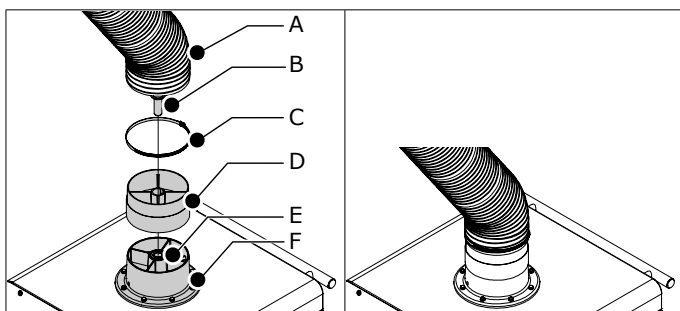

Fig. 4.7 Arm on mobile unit

For mounting of the hood:

- proceed with paragraph **4.6**

#### 4.6 Hood

Fig. 4.8

- Loosen the mounting material that is attached to the hood hinge.
- Install the extraction hood (G) with the bolt (F), 2 washers (E), 2 spring washers (D) and a locknut (C).
- Install the hood collar (H) to the hood (G). Fasten it with the clip.
- Install the hose (A) to the hood.
- Fasten the hose with a hose clamp (B).

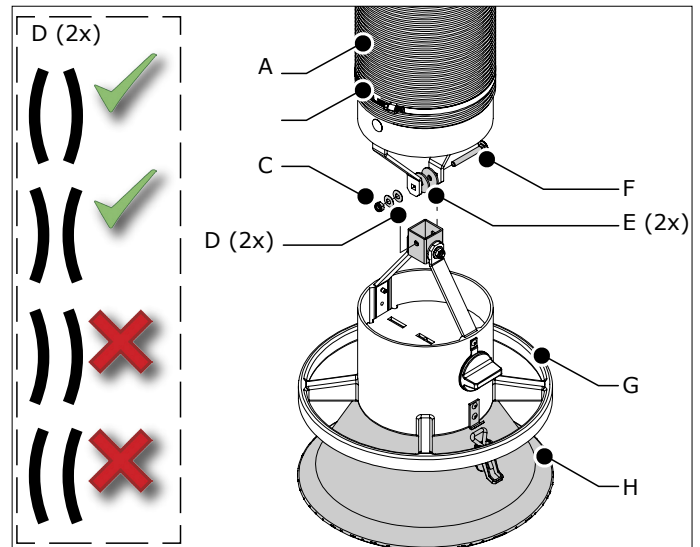

Fig. 4.8 Hood mounting

#### 4.7 KUA-160 ATEX

The KUA-160 ATEX arm is factory-wise provided with litz wires between the metal parts, including the spring steel wires of the hoses. To make the arm suitable for use in potentially explosive atmospheres, you must make an earth connection.

Fig. 4.11

- Connect the litz wire (A) to the extraction hood with the faston connector.

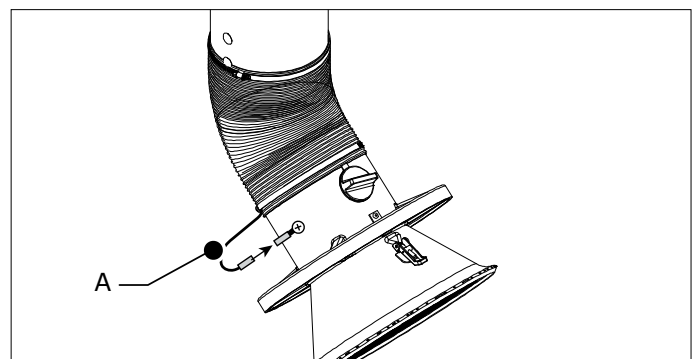

Fig. 4.9 Connection of the litz wire to the hood

Fig. 4.10

- Connect the other litz wire (A) to the extraction duct with a self-tapping screw<sup>9</sup>.
- Make sure that the rotation of the arm is not obstructed by the litz wire.

9. Size 4,2 mm



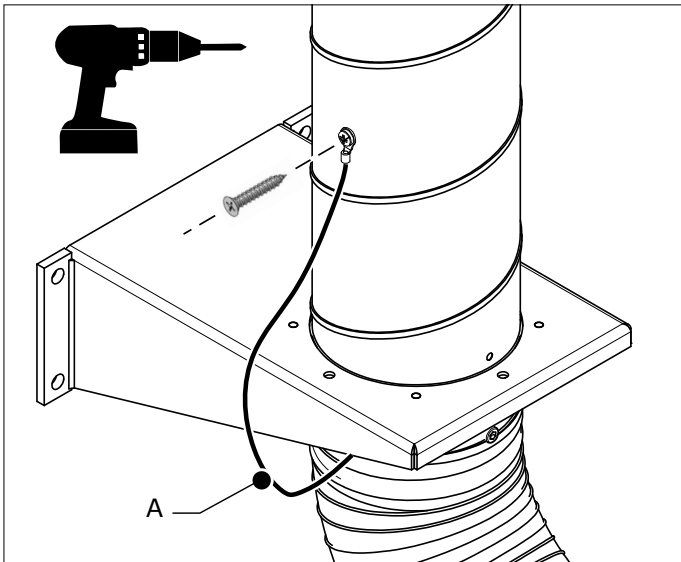

Fig. 4.10 Connection of the litz wire to the duct

Fig. 4.11

- Measure the earth connection between the hood and the duct. The electrical resistance must be lower than 10 ohm.



**ATTENTION!**

If the electrical resistance is over 10 ohm, the litz wire connection is not correct. In that case: make sure that all litz wires from the hood to the duct are interconnected.

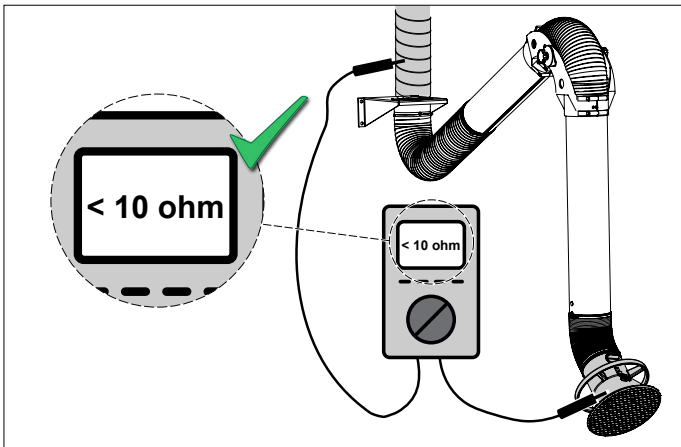

Fig. 4.11 Earth connection

**5 USE**



**Personal protective equipment (PPE)**

During use, use PPE to avoid injury. This also applies for persons who enter the work area.

**5.1 Controls**

The hood of the arm is provided with a handle for easy positioning and a valve to regulate or shut off the airflow. All movement of the arm is controlled from the hood.

Fig. 5.1

- A Sealed shut-off valve (H-D types only)
- B Control valve
- C Handle

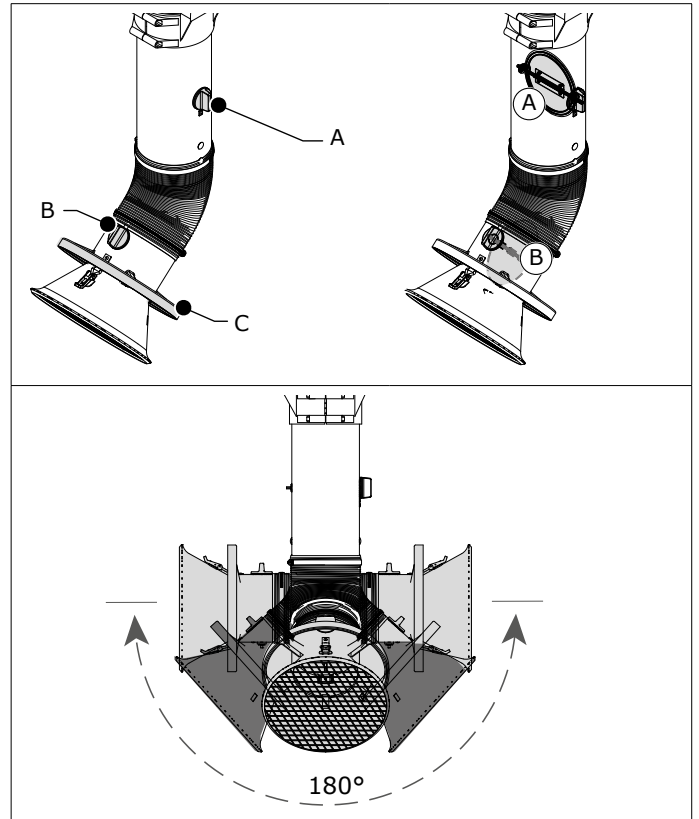

Fig. 5.1 Controls

**5.2 Use**

Fig. 5.2

- Use the handle (ref. Fig. 5.1C) to position the hood of the arm at max. 480 mm (19 in.) from the source of pollution.
- Make sure that the valve (ref. Fig. 5.1A/B) is open.
- Turn on the connected extraction fan or system.
- Start welding.
- If desired, partly close the valve to adjust the airflow.
- When the welding position changes, move the hood to the correct position in relation to the weld.
- Turn off the connected extraction fan or system approx. 20 seconds after finishing welding.

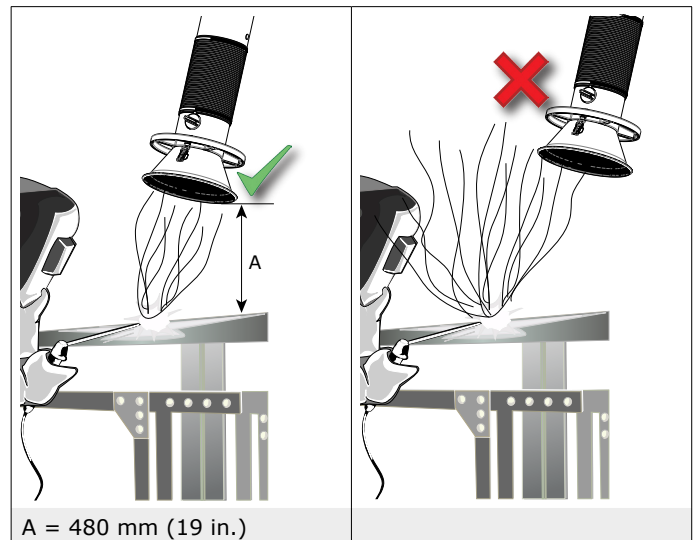

Fig. 5.2 Correct position of the hood

## 6 MAINTENANCE

### 6.1 Periodic maintenance



The product has been designed to function without problems for a long time with a minimum of maintenance. In order to guarantee this some simple, regular maintenance and cleaning activities are required which are described in this chapter. If you observe the necessary caution and carry out the maintenance at regular intervals, any problems occurring will be detected and corrected before they lead to a total breakdown.



**WARNING!**  
Overdue maintenance can cause fire.

The indicated maintenance intervals can vary depending on the specific working and ambient conditions. Therefore we recommend to thoroughly inspect the complete product once every year beside the indicated periodic maintenance. For this purpose contact your supplier.

Component	Action	Frequency: every X months	
		X=3	X=6
Outside of the arm	Clean with a non-aggressive detergent	X	
Flexible hoses	Check for cracks or damages. Replace if necessary		X
Inside of the arm	Clean thoroughly		X
Hood	Check the movement of the hood. If necessary, adjust the friction; refer to paragraph 6.2		X
Arm movement	Check horizontal, vertical and diagonal arm movement. If necessary, adjust the friction; refer to paragraph 6.2		X

### 6.2 Arm adjustment

If the extraction arm, or a part of it, does not stay in the desired position, you must adjust the friction.

Fig. 6.1

- Determine which joint needs more or less friction.
- Loosen the hose at that position to get access to the hinge<sup>10</sup>.
- Pull the arm in a horizontal position.
- Adjust the friction; refer to the images below for the adjustment points.

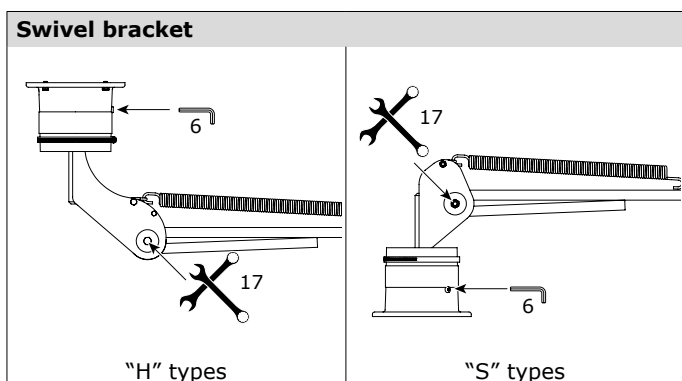

#### Middle hinge

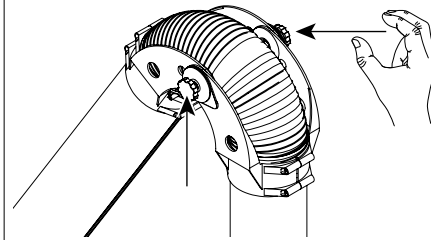

#### Hood hinge

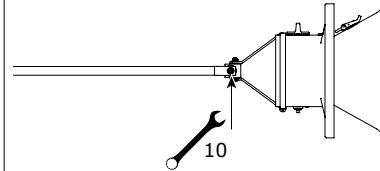

Fig. 6.1 Adjustment points

## 7 TROUBLESHOOTING

If the product does not function (correctly), consult the checklist below to see if you can remedy the error yourself. Should this not be possible, contact your supplier.



**WARNING!**  
Obey the safety regulations that are written in chapter 3 when you carry out the activities below.

Symptom	Problem	Possible cause	Solution
The extraction arm does not stay in the desired position	Escape of fume; no proper extraction	Friction setting is not correct	Adjust the friction; refer to Fig. 6.1 for the adjustment points
You cannot get the arm in the desired position			

## 8 SPARE PARTS

The following spare parts are available for the product;  
- refer to exploded view Fig. VIII on page 13



## 9 DISPOSAL

After life of the product, dispose of it in accordance with federal, state or local regulations.



10. In case of swivel bracket or hood hinge

---

---

## CE DECLARATION

### CE declaration of conformity for machinery



We, Plymovent Manufacturing B.V., Koraalstraat 9, 1812 RK Alkmaar, Netherlands, herewith declare, on our own responsibility, that the products:

- KUA-160/2H ATEX
- KUA-160/3H ATEX
- KUA-160/4H ATEX

which this declaration refers to, have been manufactured in compliance with the directions of the Directive Council of 17th of May 2006 regarding machine safety 2006/42/EC, amended by the directive 95/16/EC with special reference to appendix I regarding basic health and safety requirements in connection with the construction and manufacturing of machinery.

Applicable standards:

- EN-ISO 12100:2010 | Safety of machinery  
Basic concepts, general principles for design
- EN-IEC 60079-11:2012  
Explosive atmospheres – Part 11: Equipment protection by intrinsic safety "i"
- ISO/IEC 80079-36  
Explosive atmospheres – Part 36: Non-electrical equipment for use in explosive atmospheres

The products are approved for zone 2 (Gas) and zone 22 (Dust), in accordance with the ATEX Directive 2014/34/EU.

Classification:

- Product group: II
- Product category: 3

Marking:

- Ex II 3G
- Ex II 3D

Signature:

Name: M.S.J. Ligthart  
Position: Product Manager  
Date of issue: 1st August 2020

Fig. I Working reach

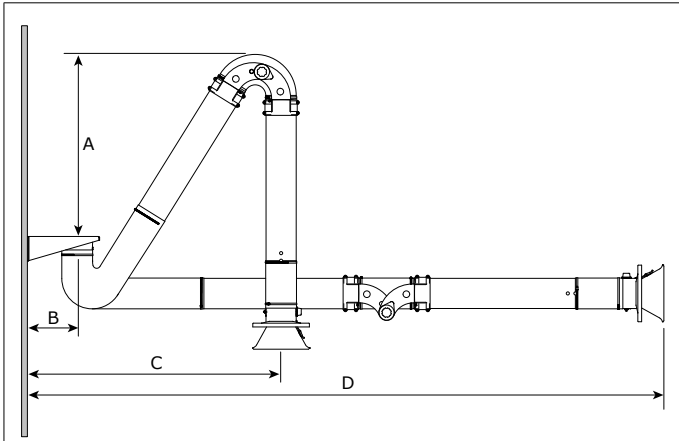

	KUA-160/2		KUA-160/3		KUA-160/4	
	mm	inch	mm	inch	mm	inch
<b>A</b>	455	18	950	37½	1250	49
<b>B</b>	265	10½	265	10½	265	10½
	min.		min.		min.	
<b>C</b>	1030	40½	1335	52½	1525	60
	max.		max.		max.	
<b>D</b>	2500	98½	3350	132	4040	159

Fig. II Pressure drop

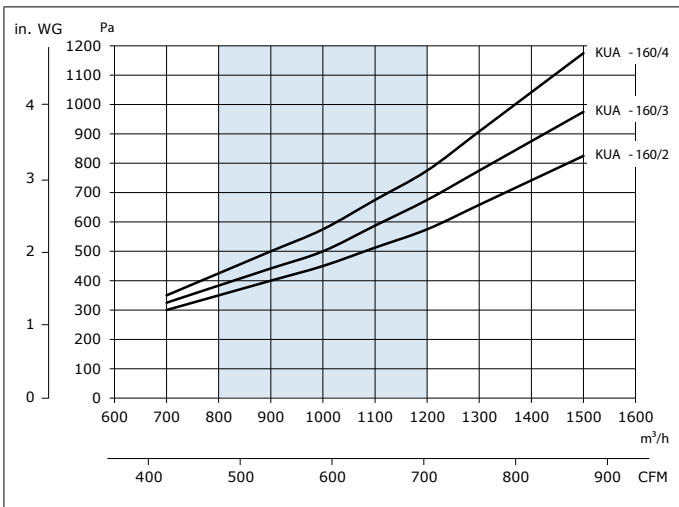

Fig. III Mounting sequence

HANGING MOUNTING			
KUA-160/H	Wall	Stanchion	Ext. crane
1. Start with	par. 4.4.1	par. 4.4.2	INS_FlexMax
2. Arm mounting	par. 4.4.3	par. 4.4.3	par. 4.4.3
3. Fan mounting	par. 4.4.4	par. 4.4.4	-
4. Hood mounting	par. 4.6	par. 4.6	par. 4.6
KUA-160/H ATEX			
KUA-160/H ATEX	Wall	Stanchion	
1. Start with	par. 4.4.1	par. 4.4.2	
2. Arm mounting	par. 4.4.3	par. 4.4.3	
3. Fan mounting	par. 4.4.4	par. 4.4.4	
4. Hood mounting	par. 4.6	par. 4.6	
5. ATEX	par. 4.7	par. 4.7	

**STANDING MOUNTING**

KUA-160/S	Stanchion	Wall bracket	Mobile unit
1. Start with	par. 4.5.1	par. 4.5.2	par. 4.5.3
2. Hood mounting	par. 4.6	par. 4.6	par. 4.6

Fig. IV Mounting examples "H" types

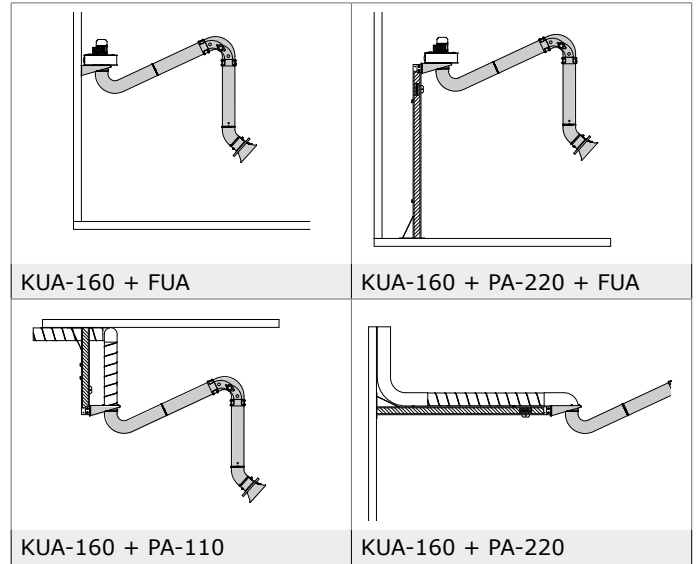

Fig. V Mounting examples "S" types

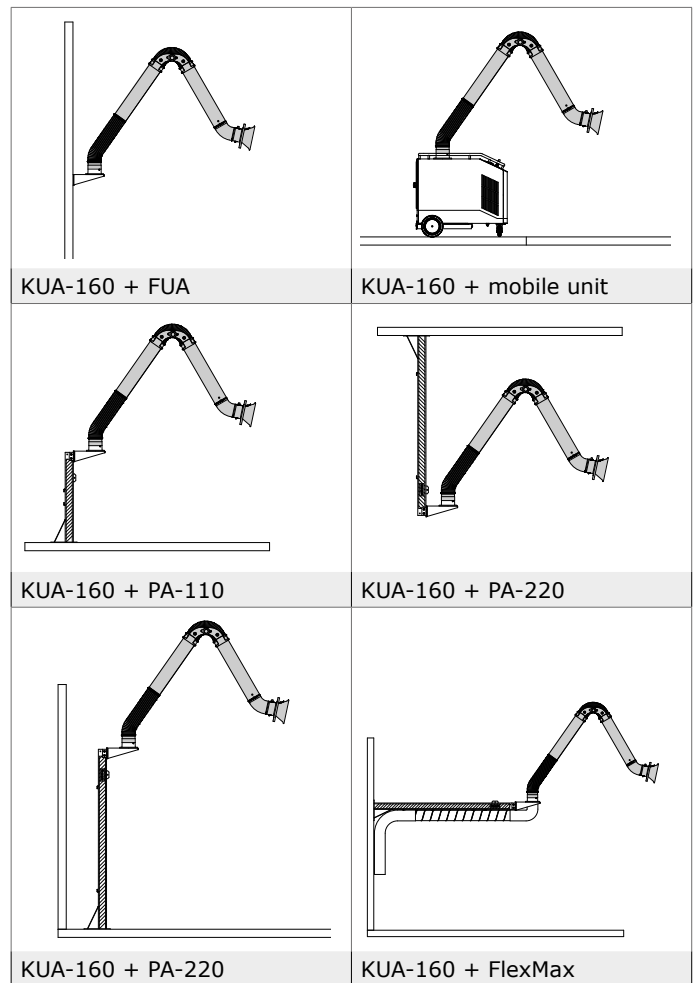

Fig. VI Stanchion

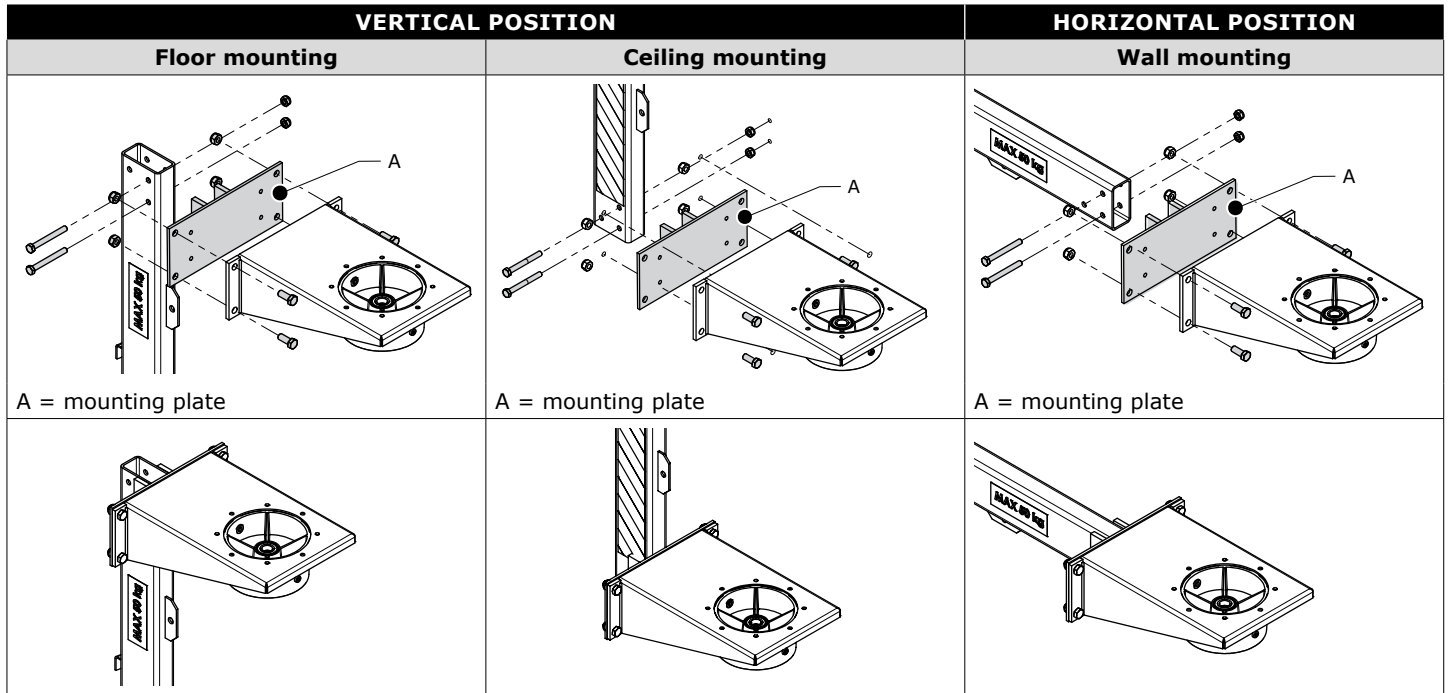

Fig. VII Dimensions and mounting measurements of the wall bracket

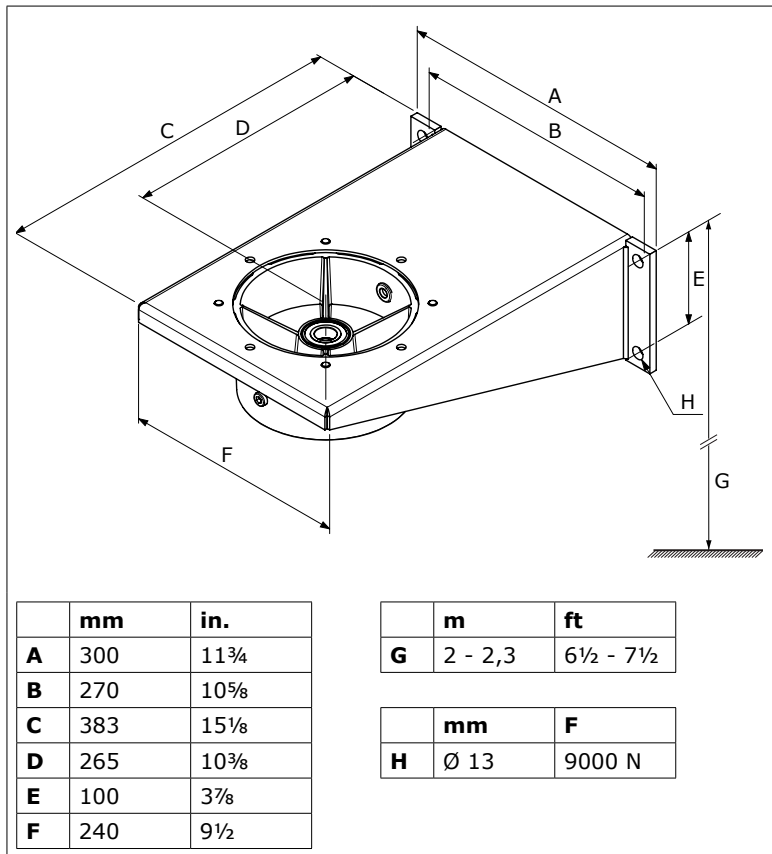
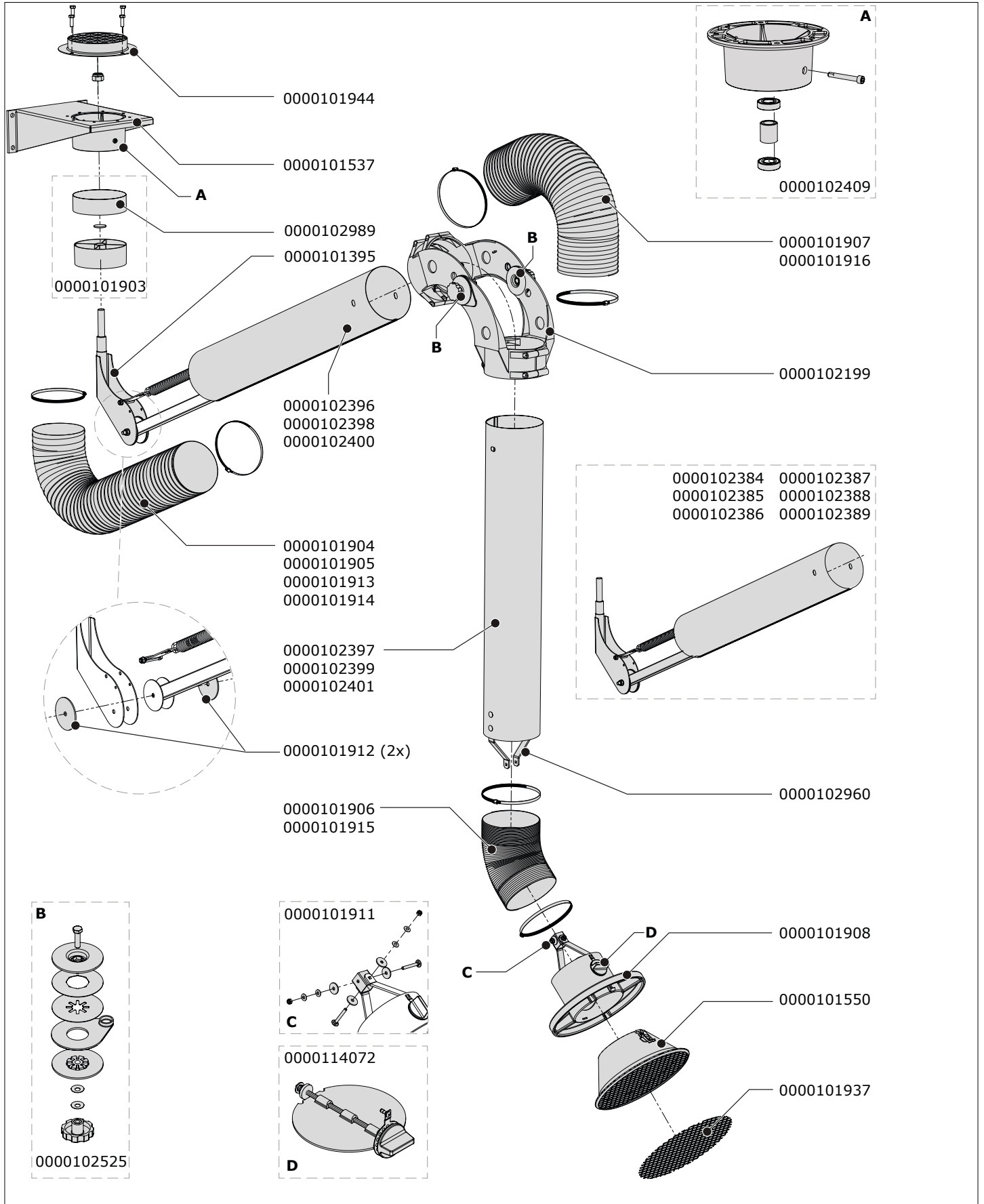

Fig. VIII Exploded view



Article no.	Description
<b>General</b>	
0000101537	Wall mounting bracket, complete
0000101550	Hood with safety mesh
0000101903	Arm swivel ring KUA-160, incl. rubber collar and washer
0000101906	Hose L=400 mm/Ø 163 mm, incl. 2 hose clamps
0000101907	Hose L=650 mm/Ø 163 mm, incl. 2 hose clamps
0000101908	Hood collar, incl. handle, damper and hood hinge
0000101911	Hood hinge, incl. mounting material
0000101912	Friction plate 83x10x3 mm (set of 2)
0000101937	Safety mesh Ø 300 mm
0000101944	Connection flange with grid
0000102199	Elbow joint KUA-160
0000102409	Rotating flange (ball bearing)
0000102525	Mounting kit for middle hinge KUA-160
0000102960	Brackets outer tube KUA (2 pcs)
0000102989	Rubber collar Ø 160 mm
0000114072	Plastic balancing damper Ø 160 mm
<b>KUA-160/2H</b>	
0000101395	Swivel bracket for KUA-160/H and EA/H
0000101904	Hose L=850 mm/Ø 163 mm, incl. 2 hose clamps
0000102384	Inner frame KUA-160/2H, complete
0000102396	Inner tube KUA-160/2
0000102397	Outer tube KUA-160/2
<b>KUA-160/3H</b>	
0000101395	Swivel bracket for KUA-160/H and EA/H
0000101905	Hose L=1000 mm/Ø 163 mm, incl. 2 hose clamps
0000102385	Inner frame KUA-160/3H, complete
0000102398	Inner tube KUA-160/3
0000102399	Outer tube KUA-160/3
<b>KUA-160/4H</b>	
0000101395	Swivel bracket for KUA-160/H and EA/H
0000101905	Hose L=1000 mm/Ø 163 mm, incl. 2 hose clamps
0000102386	Inner frame KUA-160/4H, complete
0000102400	Inner tube KUA-160/4
0000102401	Outer tube KUA-160/4
<b>KUA-160/2S</b>	
0000101904	Hose L=850 mm/Ø 163 mm, incl. 2 hose clamps
0000102387	Inner frame KUA-160/2S, complete
0000102396	Inner tube KUA-160/2
0000102397	Outer tube KUA-160/2
<b>KUA-160/3S</b>	
0000101905	Hose L=1000 mm/Ø 163 mm, incl. 2 hose clamps
0000102388	Inner frame KUA-160/3S, complete
0000102398	Inner tube KUA-160/3
0000102399	Outer tube KUA-160/3
<b>KUA-160/4S</b>	
0000101905	Hose L=1000 mm/Ø 163 mm, incl. 2 hose clamps
0000102389	Inner frame KUA-160/4S, complete
0000102400	Inner tube KUA-160/4
0000102401	Outer tube KUA-160/4
<b>KUA-160/2H ATEX</b>	
0000101395	Swivel bracket for KUA-160/H and EA/H
0000101913	Antistatic hose L=850 mm/Ø 161 mm, incl. 2 hose clamps
0000101915	Antistatic hose L=400 mm/Ø 161 mm, incl. 2 hose clamps

Article no.	Description
0000101916	Antistatic hose L=650 mm/Ø 161 mm, incl. 2 hose clamps
0000102384	Inner frame KUA-160/2H, complete
0000102396	Inner tube KUA-160/2
0000102397	Outer tube KUA-160/2
<b>KUA-160/3H ATEX</b>	
0000101395	Swivel bracket for KUA-160/H and EA/H
0000101914	Antistatic hose L=1000 mm/Ø 161 mm, incl. 2 hose clamps
0000101915	Antistatic hose L=400 mm/Ø 161 mm, incl. 2 hose clamps
0000101916	Antistatic hose L=650 mm/Ø 161 mm, incl. 2 hose clamps
0000102385	Inner frame KUA-160/3H, complete
0000102398	Inner tube KUA-160/3
0000102399	Outer tube KUA-160/3
<b>KUA-160/4H ATEX</b>	
0000101395	Swivel bracket for KUA-160/H and EA/H
0000101914	Antistatic hose L=1000 mm/Ø 161 mm, incl. 2 hose clamps
0000101915	Antistatic hose L=400 mm/Ø 161 mm, incl. 2 hose clamps
0000101916	Antistatic hose L=650 mm/Ø 161 mm, incl. 2 hose clamps
0000102386	Inner frame KUA-160/4H, complete
0000102400	Inner tube KUA-160/4
0000102401	Outer tube KUA-160/4

