

Discharge rectangular duct connection



Discharge circular duct connection

Range of single inlet direct drive centrifugal fans manufactured by injection moulding. Antistatic polypropylene housing. Motor support and anticorrosive gaskets material providing protection against possible gas leakage. High-performance antistatic polypropylene impeller with forward curved blades. Working temperature from -10°C to +50°C.

Motors

All motors are IP55, class F insulation. Available in 2, 4 or 6 poles. Electrical supply: Three phase 230/400V-50Hz. (See characteristics chart).

ATEX

ATEX versions available for 3-phase models. For ambient working temperature -10°C to +40°C. Motor IP55, Class F. - ATEX Flameproof - Gas
 Ⓜ II 2G Exd IIB T4
 Ⓜ II 2G Exd IIB+H2 T4 (with motor Exd IIC T4)

To select CMPT ATEX refer to performance data, or Easyvent. Note electrical data may vary for ATEX motor

Additional information

The mounting frames are manufactured from: Nylon (models from 14 to 25). Polypropylene (models 30 and 35). Galvanised sheet steel (model 42). Standard supplied position: LG 0. The scroll can be oriented in 8 different positions. Screws in stainless steel.

Specific applications



Corrosive atmospheres

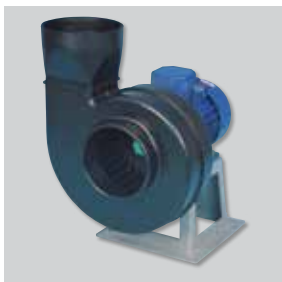

Discharge circular duct connection
 For models CMPT-14, CMPT-20 and CMPT-25.

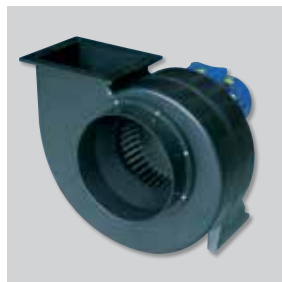

Discharge rectangular duct connection
 For models CMPT-30, CMPT-35, CMPT-42 and CMPT-20A
 * On request, CMPT-14, CMPT- 20 and CMPT-25 are also available with discharge rectangular duct connection.

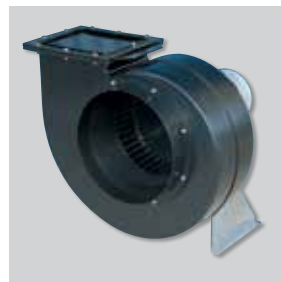

Tough and quality design
 Antistatic polypropylene housing. Screws in stainless steel.



Forward curved centrifugal impeller
 High-performance antistatic polypropylene impeller with forward curved blades.

POSITIONS

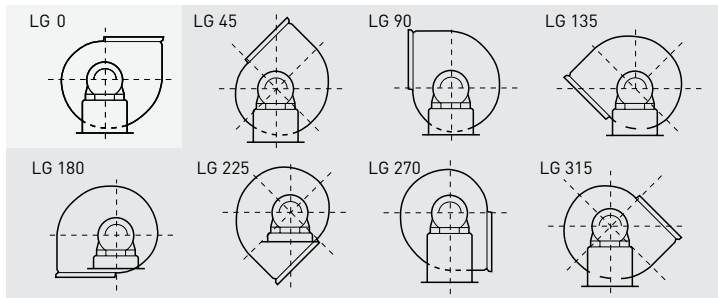

LG 0 standard supplied position. Other LG positions configuration manufactured on request.

TECHNICAL CHARACTERISTICS

Before installation check that the product electrical characteristics listed on the data plate label (voltage, power, frequency, etc.) match those of the intended electrical supply.

Model	Speed (rpm)	Motor size (mm)	Motor power (kW)	Maximum absorbed current (A)		Maximum airflow (m³/h)	Sound pressure level* (dB(A))	Weight (kg)
				230 V	400 V			
THREE PHASE 2 POLE								
CMPT/2-14-0,18 Exd IIB T4	2900	63	0,18	0,97	0,56	730	60	4,5
CMPT/2-20-1,1 Exd IIB T4	2900	80	1,1	4,33	2,5	2.100	72	13
CMPT/2-20A-0,55 Exd IIB T4	2900	71	0,55	2,34	1,35	900	68	11
THREE PHASE 4 POLE								
CMPT/4-14-0,18 Exd IIB T4	1450	63	0,18	1,09	0,63	350	45	4,5
CMPT/4-20-0,18 Exd IIB T4	1450	63	0,18	1,09	0,63	1.220	60	8
CMPT/4-25-0,55 Exd IIB T4	1450	80	0,55	2,42	1,4	2.680	60	15
CMPT/4-30-1,1 Exd IIB T4	1450	90	1,1	4,49	2,59	4.240	69	29
CMPT/4-35-3 Exd IIB T4	1450	100	3	11,22	6,48	6.470	72	48
CMPT/4-42-5,5 Exd IIB T4	1450	132	5,5	–	11,1	8.500	75	88
CMPT/4-42-7,5 Exd IIB T4	1450	132	7,5	–	14,8	11.220	80	102
CMPT/4-20A-0,25 Exd IIB T4	1450	63	0,25	1,09	0,63	530	54	9
THREE PHASE 6 POLE								
CMPT/6-20-0,09 Exd IIB T4	950	71	0,09	1,11	0,64	850	51	8
CMPT/6-25-0,37 Exd IIB T4	950	80	0,37	1,11	0,64	1.810	51	13
CMPT/6-30-0,37 Exd IIB T4	950	80	0,37	1,8	1,04	2.760	60	25
CMPT/6-35-1,5 Exd IIB T4	950	90	1,5	5,63	3,25	4.780	64	42
CMPT/6-42-3 Exd IIB T4	950	132	3	11,95	6,9	8.330	71	88

* Sound pressure dB(A), measured in free field conditions at a distance of 1,5 meters.

ACOUSTIC CHARACTERISTICS

Sound power at the inlet and outlet at three points of the curve: low pressure (B), medium pressure (M) and high pressure (H).

2 POLE MOTORS

Model 2-14		63	125	250	500	1.000	2.000	4.000	8.000	LwA
ASP	B	47	52	68	67	73	73	71	66	78
	M	51	49	66	64	69	69	66	61	74
	H	52	49	65	63	68	68	64	60	73
DES	B	51	52	64	75	82	73	72	67	84
	M	51	50	62	72	80	70	69	64	81
	H	52	48	61	69	75	67	66	61	77

CMPT/2-20A		63	125	250	500	1.000	2.000	4.000	8.000	LwA
ASP	M	53	57	69	71	81	72	69	65	82
	H	52	56	68	70	80	71	68	64	81
DES	M	60	54	67	79	91	73	69	63	91
	H	60	55	67	79	91	72	68	63	91

Model 2-20		63	125	250	500	1.000	2.000	4.000	8.000	LwA
ASP	M	45	58	68	75	81	83	80	76	87
	H	47	60	70	75	79	80	77	74	85
DES	M	47	58	69	79	82	85	81	77	89
	H	47	56	71	81	80	83	78	75	87

4 POLE MOTORS

Model 4-14		63	125	250	500	1.000	2.000	4.000	8.000	LwA
ASP	B	32	37	53	52	58	58	56	51	63
	M	36	34	51	49	54	54	51	46	59
	H	37	34	50	48	53	53	49	45	58
DES	B	36	37	49	60	67	58	57	52	69
	M	36	35	47	57	65	55	54	49	66
	H	37	33	46	54	60	52	51	46	62

CMPT/4-20A		63	125	250	500	1.000	2.000	4.000	8.000	LwA
ASP	B	38	42	55	57	68	58	55	51	69
	M	38	42	54	56	66	57	54	50	67
	H	37	41	53	55	65	56	53	49	66
DES	B	44	41	51	67	77	61	56	50	78
	M	45	39	52	64	76	58	54	48	76
	H	45	40	52	64	76	57	53	48	76

Model 4-20		63	125	250	500	1.000	2.000	4.000	8.000	LwA
ASP	B	43	56	66	71	73	69	65	62	77
	M	37	47	59	69	70	65	62	57	74
	H	37	48	59	66	66	60	56	51	70
DES	B	41	50	63	75	73	69	66	63	78
	M	37	45	58	72	70	65	63	59	75
	H	38	44	59	70	65	61	58	58	72

Model 4-25		63	125	250	500	1.000	2.000	4.000	8.000	LwA
ASP	B	46	59	65	71	77	71	70	66	80
	M	43	56	63	67	73	67	66	62	76
	H	50	57	59	63	69	63	62	57	72
DES	B	49	58	65	76	79	76	75	71	83
	M	45	54	62	73	76	71	70	66	79
	H	48	53	59	69	69	63	63	58	73

Model 4-30		63	125	250	500	1.000	2.000	4.000	8.000	LwA
ASP	B	53	71	73	81	81	78	76	72	86
	M	52	66	69	78	78	75	73	69	83
	H	54	64	65	76	77	73	71	66	81
DES	B	54	65	75	82	82	79	77	72	87
	M	53	63	71	79	80	76	74	69	84
	H	51	59	68	76	76	73	71	65	81

Model 4-35		63	125	250	500	1.000	2.000	4.000	8.000	LwA
ASP	M	54	66	70	80	83	80	79	73	87
	H	55	68	70	78	80	77	75	70	84
DES	M	57	66	74	81	86	82	80	72	89
	H	57	66	74	80	84	78	76	69	87

Model 4-42		63	125	250	500	1.000	2.000	4.000	8.000	LwA
ASP	M	60	72	79	87	90	88	85	81	94
	H	66	71	74	82	84	82	80	75	89
DES	M	66	73	82	88	92	89	86	79	96
	H	67	71	79	82	85	83	80	72	89

6 POLE MOTORS

Model 6-20		63	125	250	500	1.000	2.000	4.000	8.000	LwA
ASP	B	26	39	48	56	62	63	62	58	68
	M	21	34	44	51	57	59	56	52	63
	H	23	36	46	51	55	56	53	50	61
DES	B	29	38	48	59	62	65	62	58	69
	M	23	34	45	55	58	61	57	53	65
	H	23	32	47	57	56	59	54	51	63

Model 6-25		63	125	250	500	1.000	2.000	4.000	8.000	LwA
ASP	B	37	50	56	62	68	62	61	57	71
	M	34	47	54	58	64	58	57	53	67
	H	41	48	50	54	60	54	53	48	63
DES	B	40	49	56	67	70	67	66	62	74
	M	36	45	53	64	67	62	61	57	70
	H	39	44	50	60	60	54	54	49	64

Model 6-30		63	125	250	500	1.000	2.000	4.000	8.000	LwA
ASP	B	44	62	64	72	72	69	67	63	77
	M	43	57	60	69	69	66	64	60	74
	H	45	55	56	67	68	64	62	57	72
DES	B	45	56	66	73	73	70	68	63	78
	M	44	54	62	70	71	67	65	60	75
	H	42	50	59	67	67	64	62	56	72

Model 6-35		63	125	250	500	1.000	2.000	4.000	8.000	LwA
ASP	B	46	57	63	73	77	75	73	68	81
	M	45	57	61	71	74	71	70	64	78
	H	46	59	61	69	71	68	66	61	75
DES	B	52	59	67	74	80	76	74	67	83
	M	48	57	65	72	77	73	71	63	80
	H	48	57	65	71	75	69	67	60	78

Model 6-42		63	125	250	500	1.000	2.000	4.000	8.000	LwA
ASP	B	51	64	72	81	84	82	80	75	88
	M	51	63	70	78	81	79	76	72	85
	H	57	62	65	73	75	73	71	66	80
DES	B	58	66	76	81	86	84	81	75	90
	M	57	64	73	79	83	80	77	70	87
	H	58	62	70	73	76	74	71	63	80

PERFORMANCE CURVES

- q_v : Airflow in m^3/h and m^3/s
- p_{sf} : Static pressure in Pa
- P: input power in W
- Sound pressure level in dB(A) at 1,5m, at the fan inlet in free field condition
- Dry air at 20°C and 760 mmHg
- Performance data in accordance with ISO 5801 and AMCA 210-99 Standards

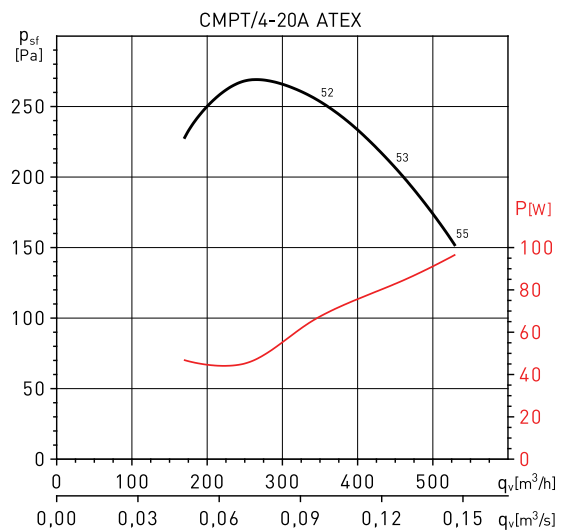
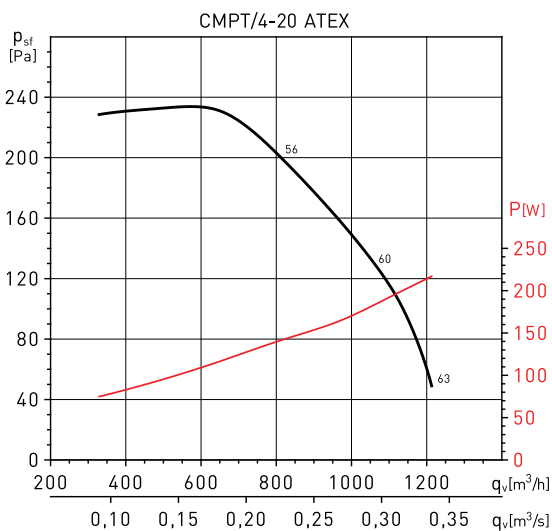
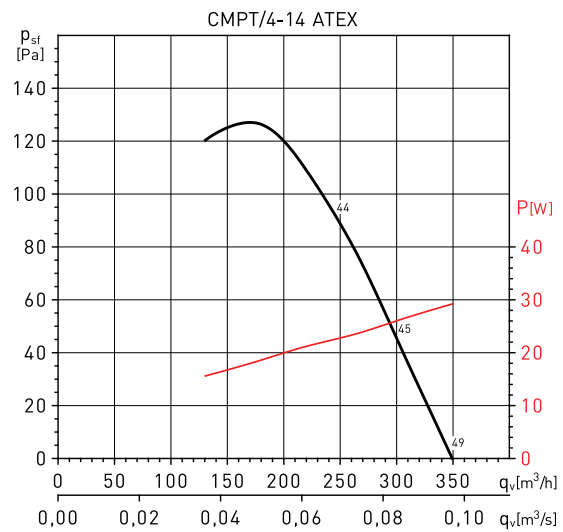
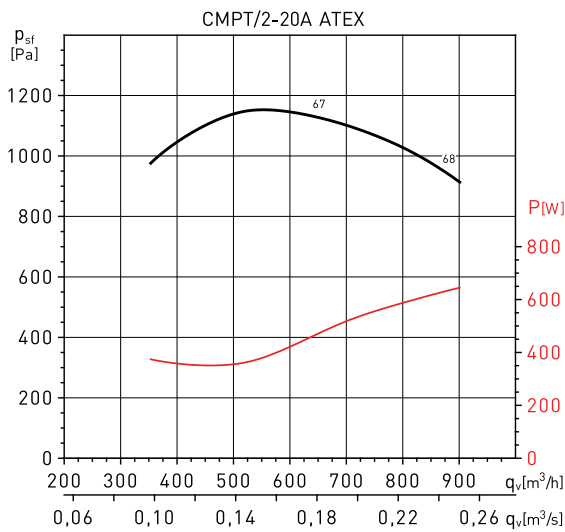
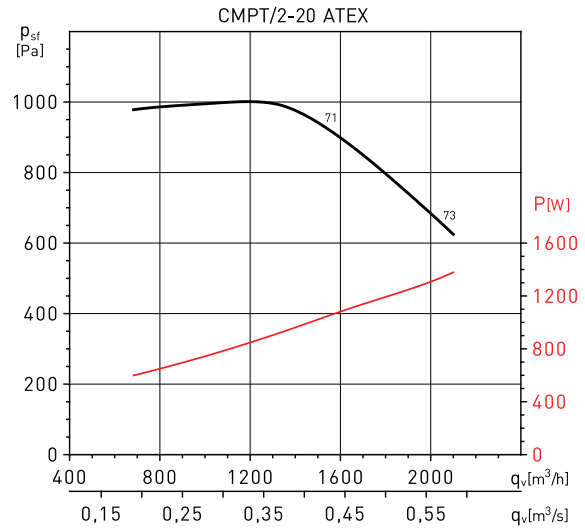
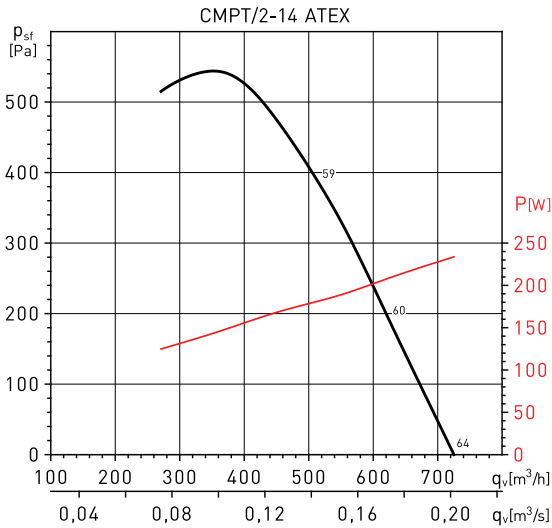

PERFORMANCE CURVES

- q_v : Airflow in m^3/h and m^3/s
- p_{sf} : Static pressure in Pa
- P: input power in W
- Sound pressure level in dB(A) at 1,5m, at the fan inlet in free field condition
- Dry air at 20°C and 760 mmHg
- Performance data in accordance with ISO 5801 and AMCA 210-99 Standards

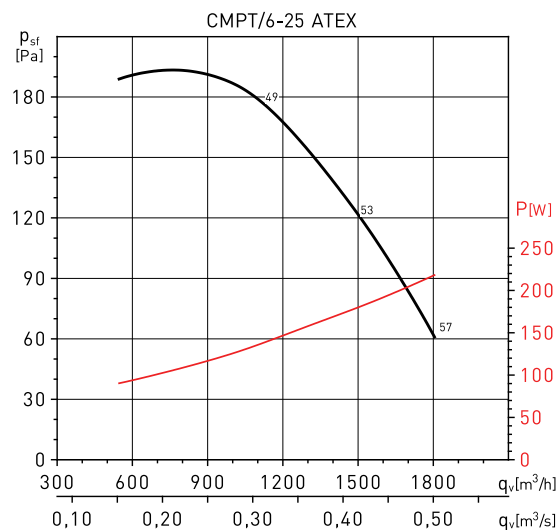
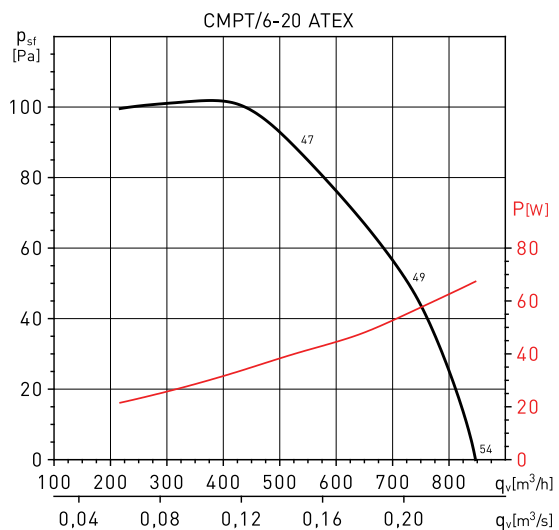
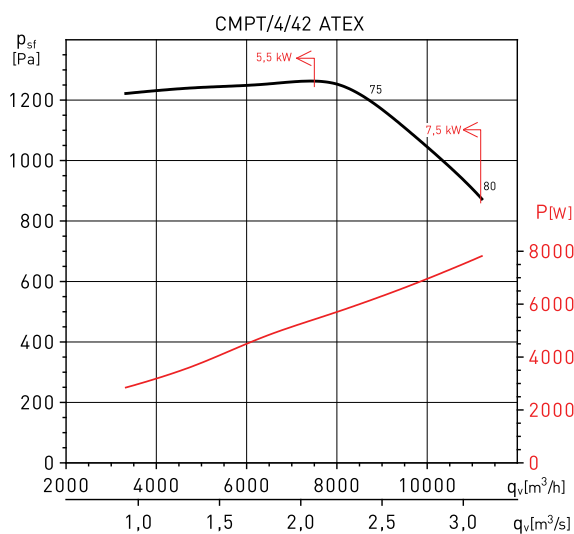
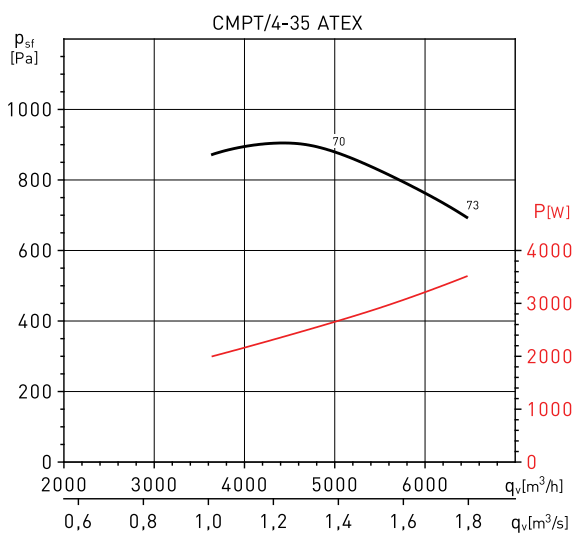
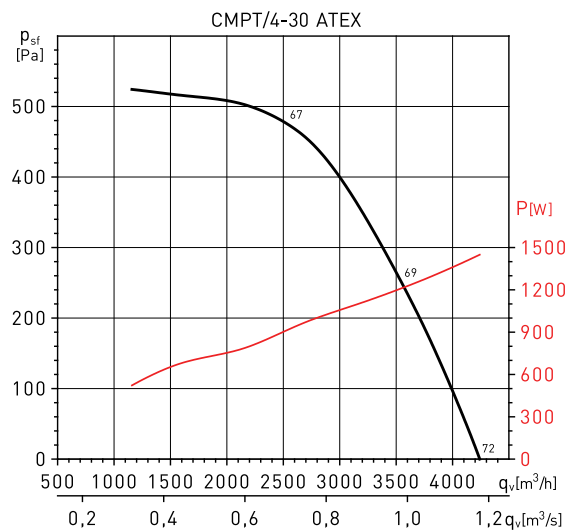
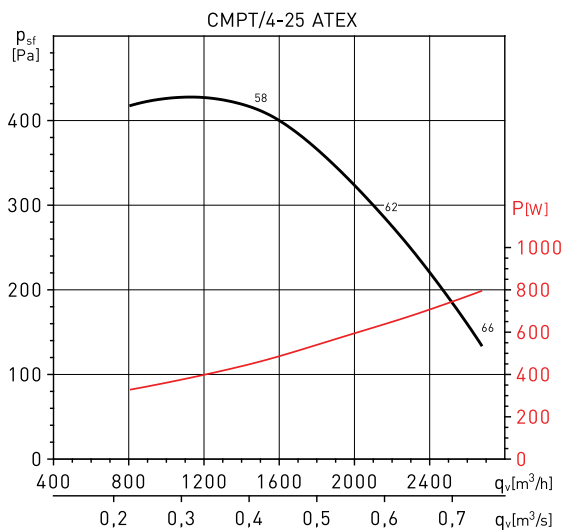

PERFORMANCE CURVES

- q_v : Airflow in m^3/h and m^3/s
- p_{sf} : Static pressure in Pa
- P: input power in W
- Sound pressure level in dB(A) at 1,5m, at the fan inlet in free field condition
- Dry air at 20°C and 760 mmHg
- Performance data in accordance with ISO 5801 and AMCA 210-99 Standards

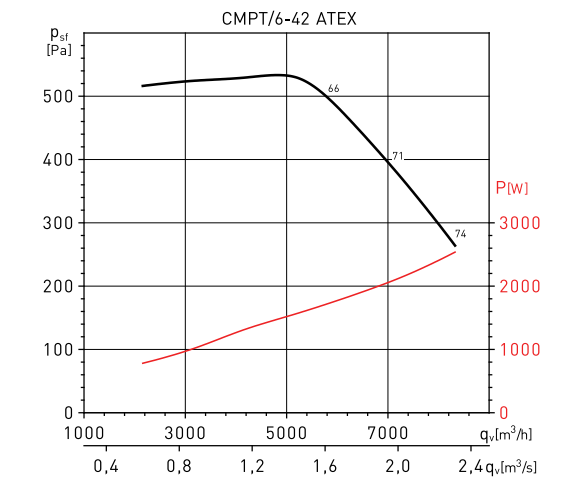
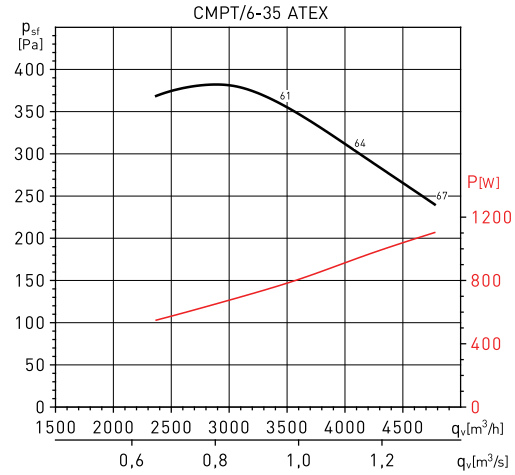
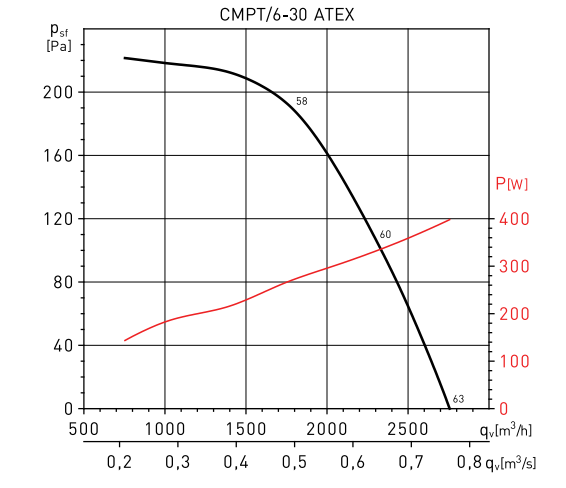

DIMENSIONS (mm)

CMPT 14, 20 and 25

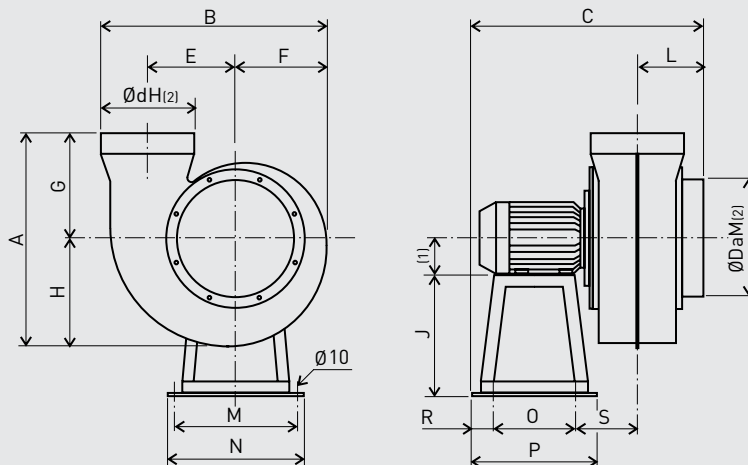

(1) Motor size: for dimensions, see technical characteristics. (2) M: Male flange, H: Female flange

Model	A	B	C	Da	E	F	G	H	J	L	M	N	O	P	R	S	a	b	d
CMPT 14	325	284	317	125	103	118	189	136	130	72	175	200	130	200	35	80	-	-	125
CMPT 20	501	418	420	200	148	170	300	201	200	120	215	240	170	240	35	95	-	-	200
CMPT 25	570	520	487	250	185	210	320	250	250	129	255	280	175	280	53	130	-	-	250

DIMENSIONS (mm)

CMPT 20A

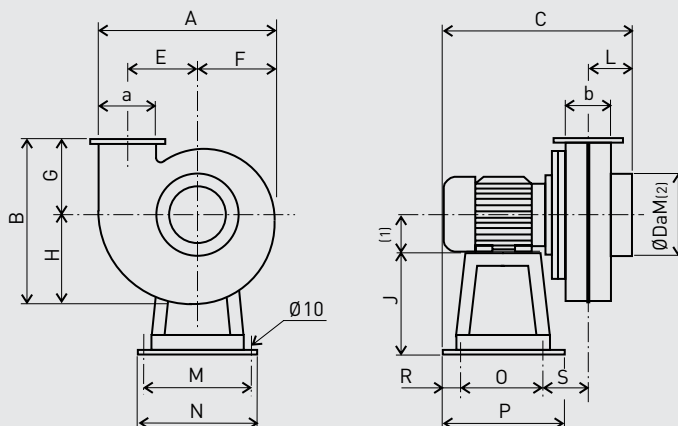

(1) Motor size: for dimensions, see technical characteristics. (2) M:Male flange.

Model	A	B	C	Da	E	F	G	H	J	L	M	N	O	P	R	S	a	b
CMPT 20A	349	325	370	160	140	157	148	177	200	85	215	240	170	240	35	80	105	90

CMPT 30, 35 and 42

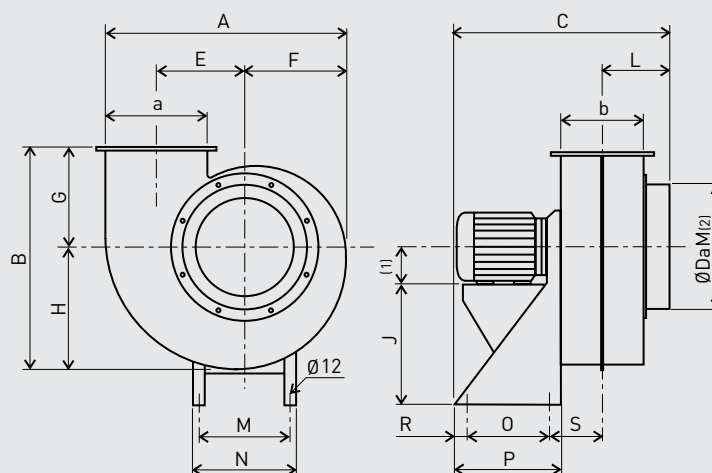

(1) Motor size: for dimensions, see technical characteristics. (2) M:Male flange.

Model	A	B	C	Da	E	F	G	H	J	L	M	N	O	P	R	S	a	b
CMPT 30	593	515	565	315	222	251	215	300	310	185	234	260	175	275	50	155	240	195
CMPT 35	696	626	660	355	259	297	275	353	320	210	285	380	200	300	50	170	280	225
CMPT 42	835	724	810	400	310	357	300	424	410	245	315	350	250	350	50	197	335	270